

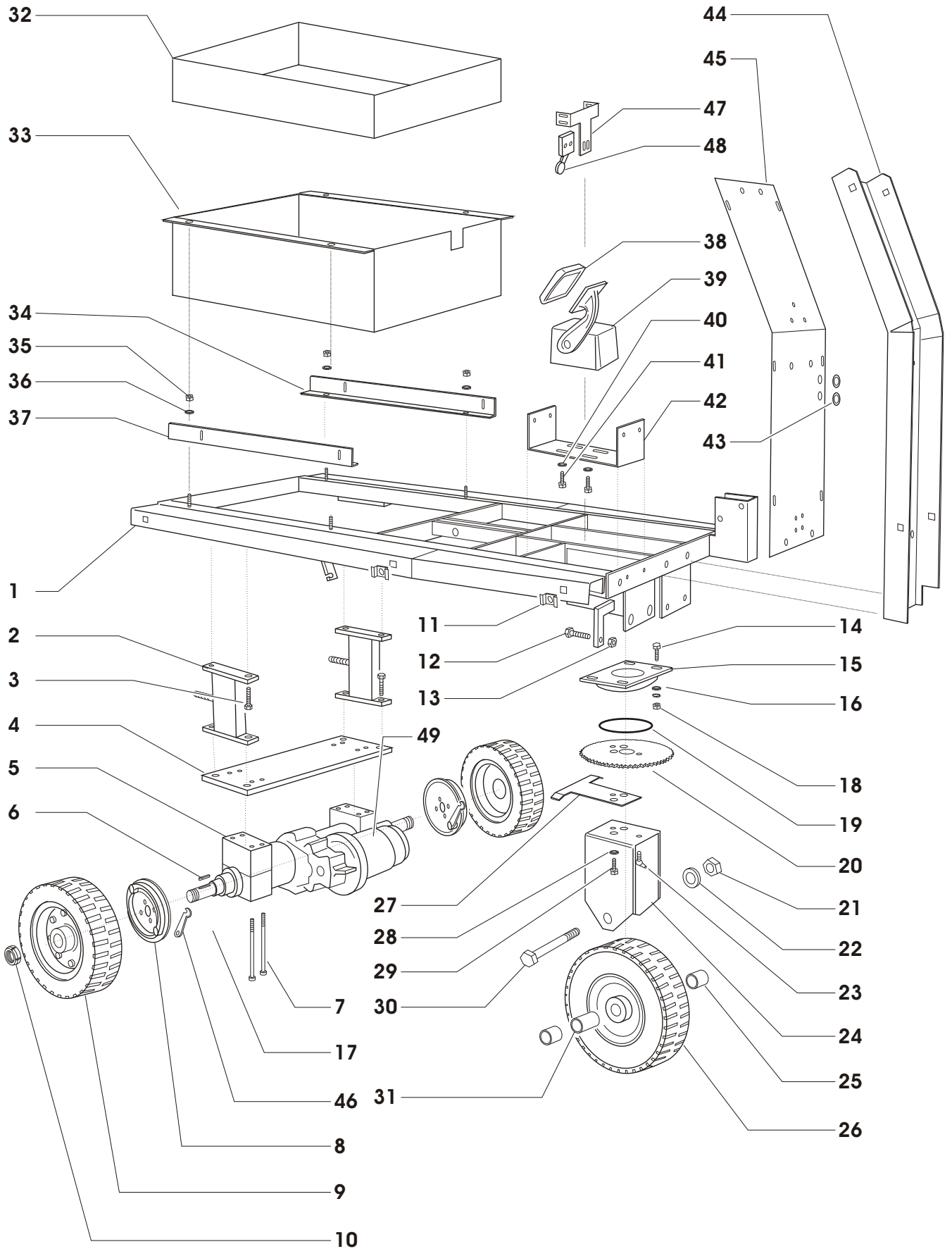

Pos.	Cod. n°	Descrizione	Description	Designation	Benennung	Denominacion
1	710.001	TELAIO	FRAME	CHASSIS	RAHMEN	BASTIDOR
2	710.002	SUPPORTO	SUPPORT	SUPPORT	STÜTZE	SOPORTE
3	430.234	VITE	SCREW	VIS	SCHRAUBE	TORNILLO
4	710.004	PIASTRA	PLATE	PLAQUE	PLATTE	PLACA
5	710.005	MOTORIDUTTORE	REDUCER MOTOR	REDUCTEUR - MOTEUR	REDUZIERER-MOTOR	REDUCTOR-MOTOR
6	710.006	LINGUETTA	TANG	LANGUETTE	FEDERKEIL	LANGUETA
7	710.007	VITE	SCREW	VIS	SCHRAUBE	TORNILLO
8	1000.027	FRENO	BRAKE	FREIN	BREMSE	FRENO
9	710.009	RUOTA	WHEEL	ROUE	RAD	RUEDA
10	710.010	GHIERA	RING NUT	EMBOUT	DER RING	ABRAZADERA
11	430.063	DADO IN GABBIA	CAGE NUT	ECROU A CAGE	MUTTERKAEFIG	TUERCA A JAULA
12	430.176	VITE	SCREW	VIS	SCHRAUBE	TORNILLO
13	700.124	DADO	NUT	ECROU	MUTTER	TUERCA
14	430.234	VITE	SCREW	VIS	SCHRAUBE	TORNILLO
15	710.015	SUPPORTO	SUPPORT	SUPPORT	STÜTZE	SOPORTE
16	430.171	RONDELLA	WASHER	RONDELLE	UNTERLEGSSCHEIBE	ARANDELA
17	1000.008	FORCELLA	FORK	FOURCHE	GABEL	HORQUILLA
18	700.124	DADO	NUT	ECROU	MUTTER	TUERCA
19	710.019	GUARNIZIONE	SEAL	JOINT	DICHTUNG	JUNTA
20	710.020	CORONA	CROWN WHEEL	COURONNE	DIE KRONE	CORONA
21	710.021	DADO	NUT	ECROU	MUTTER	TUERCA
22	710.022	RONDELLA	WASHER	RONDELLE	UNTERLEGSSCHEIBE	ARANDELA
23	710.023	INGRASSATORE	GREASER	GRAISSEUR	SCHMIERER	LUBRIFICADOR
24	710.024	SUPPORTO	SUPPORT	SUPPORT	STÜTZE	SOPORTE
25	710.025	DISTANZIALE	SPACER	ENTRETOISE	DISTANZSTÜCK	SEPARADOR
26	710.026	RUOTA	WHEEL	ROUE	RAD	RUEDA
27	710.027	PIASTRA	PLATE	PLAQUE	PLATTE	PLACA
28	710.028	RONDELLA	WASHER	RONDELLE	UNTERLEGSSCHEIBE	ARANDELA
29	710.029	VITE	SCREW	VIS	SCHRAUBE	TORNILLO
30	710.030	VITE	SCREW	VIS	SCHRAUBE	TORNILLO
31	710.031	DISTANZIALE	SPACER	ENTRETOISE	DISTANZSTÜCK	SEPARADOR
32	710.032	VASCHETTA PE	VAT PE	CUVE PE	WANNE PE	CUBA PE
33	710.033	VASCHETTA	VAT	CUVE	WANNE	CUBA
34	710.034	LISTADI FERMO	STOP STRIP	BARRE D'ARRET	SPERRLEISTE	TOPE
35	430.182	DADO	NUT	ECROU	MUTTER	TUERCA
36	430.118	RONDELLA	WASHER	RONDELLE	UNTERLEGSSCHEIBE	ARANDELA
37	710.037	LISTADI FERMO	STOP STRIP	BARRE D'ARRET	SPERRLEISTE	TOPE
38	500.154	GOMMA	RUBBER	CAOUTCHOUC	GUMMI	GOMA
39	1000.328	ACCELERATORE	ACCELERATOR	ACCELERATEUR	GASREGULIERUNG	ACELERADOR
40	710.040	RONDELLA	WASHER	RONDELLE	UNTERLEGSSCHEIBE	ARANDELA
41	710.041	VITE	SCREW	VIS	SCHRAUBE	TORNILLO
42	1000.063	SUPPORTO	SUPPORT	SUPPORT	STÜTZE	SOPORTE
43	710.043	GOMMA	RUBBER	CAOUTCHOUC	GUMMI	GOMA
44	710.044	SUPPORTO	SUPPORT	SUPPORT	STÜTZE	SOPORTE
45	710.045	PIASTRA	PLATE	PLAQUE	PLATTE	PLACA
46						
47	710.047	SUPPORTO	SUPPORT	SUPPORT	STÜTZE	SOPORTE
48	1000.082	MICRO	MICRO	MICRO	MIKRO	MICRO
49	710.005.1	MOTORE	MOTOR	MOTEUR	MOTOR	MOTOR





Pos.	Cod. n°	Descrizione	Description	Designation	Benennung	Denominacion
70	430.066.B	MOTORIDUTTORE	REDUCER MOTOR	REDUCTEUR-MOTEUR	REDUZIERER-MOTOR	REDUCTOR-MOTOR
71	710.071	SUPPORTO	SUPPORT	SUPPORT	STÜTZE	SOPORTE
72	810.072	LEVA	LEVER	LEVIER	HEBEL	PALANCA
73	710.073	SUPPORTO	SUPPORT	SUPPORT	STÜTZE	SOPORTE
74	500.200	DADO	NUT	ECROU	MUTTER	TUERCA
75	430.171	RONDELLA	WASHER	RONDELLE	UNTERLEGSSCHEIBE	ARANDELA
76	430.234	VITE	SCREW	VIS	SCHRAUBE	TORNILLO
77	850.308	LISTA PARASPRUZZI	SPLASH GUARD STRIP	BARRE ECRAN ANTI-ECLABOUSSURES	LEISTE - SPRITZBLECH	TOPE GUARDA - SALPICONES
78	501.047	VITE	SCREW	VIS	SCHRAUBE	TORNILLO
79	501.048	GANCIO	HOOK	CROCHET	HAKEN	GANCHO
80	810.080	PIASTRA	PLATE	PLAQUE	PLATTE	PLACA
81	1000.131	DADO	NUT	ECROU	MUTTER	TUERCA
82	430.182	DADO	NUT	ECROU	MUTTER	TUERCA
83	430.118	RONDELLA	WASHER	RONDELLE	UNTERLEGSSCHEIBE	ARANDELA
84	710.084	PIASTRA	PLATE	PLAQUE	PLATTE	PLACA
85	430.173	VITE	SCREW	VIS	SCHRAUBE	TORNILLO
86	710.086	PIASTRA	PLATE	PLAQUE	PLATTE	PLACA
87	710.087	SUPPORTO	SUPPORT	SUPPORT	STÜTZE	SOPORTE
88	710.088	BOCCOLA	BUSHING	DOUILLE	BÜCHSE	BUJE
89						
90						
91	710.091	ATTUATORE	ACTUATOR	ACTUATEUR	ANTRIEB	ACTIVADOR
92	500.200	DADO	NUT	ECROU	MUTTER	TUERCA
93	710.093	RONDELLA NYLON	NYLON WASHER	RONDELLE EN NYLON	NYLON UNTERLEGSSCHEIBE	ARANDELA NYLON
94	1000.129	VITE	SCREW	VIS	SCHRAUBE	TORNILLO
95	430.234	VITE	SCREW	VIS	SCHRAUBE	TORNILLO
96						
97	850.317	DADO	NUT	ECROU	MUTTER	TUERCA
98	500.023	RUOTA PARACOLPI	BUFFER WHEEL	ROUE - BUTEE	PRELLRAD	RUEDA GUARDACHOQUES
99	430.176	VITE	SCREW	VIS	SCHRAUBE	TORNILLO
100	430.010	PARASPRUZZI	SPLASH GUARD	ECRAN ANTI - ECLABOUSSURES	SPRITZBLECH	FALDOM
101	850.306	VITE	SCREW	VIS	SCHRAUBE	TORNILLO
102	430.074.1	GIUNTO	COUPLING	JOINT	KUPPLUNG	EMPALME
103	430.073	GRANO	DOWEL	GOUJON	ZAPFEN	GRANO
104	430.075	VITE	SCREW	VIS	SCHRAUBE	TORNILLO
105	430.076.1	SUPPORTO CON MOLLA	SUPPORT WITH SPRING	SUPPORT AVEC RESSORT	STÜTZEFEDER	SOPORTE RESORTE
106	410.068	SPAZZOLA NYLON	NYLON BRUSH	BROSSE EN NYLON	NYLONBURSTE	CEPILLO NYLON
106	410.068.1	SPAZZOLA TYNEX	TINEX BRUSH	BROSSE EN TINEX	TINEXBURSTE	CEPILLO TINEX
106	410.068.2	SPAZZOLA ACCIAIO	STEEL BRUSH	BROSSE EN ACIER	STAHLBURSTE	CEPILLO ACERO
106	410.068.3	SPAZZOLA VEGETALE	VEGETABLE BRUSH	BROSSE VEGETAL	VEGETALBURSTE	CEPILLO VEGETAL
106	410.068.4	TRASCINATORE	CONVEYOR	ENTAINEMENT	MITNEHMER	CINTA DE ARRASTRE
106	410.068.5	DISCO ABRASIVO	ABRASIVE DISK	DISQUE ABRASIF	REIBE SCHALLPLATTE	DISCO ABRASIVO
107	430.079	VITE	SCREW	VIS	SCHRAUBE	TORNILLO
108	430.078	DADO	NUT	ECROU	MUTTER	TUERCA
109	1000.126	CAMMA	CAM	CAME	NOCKEN	CAMA
110	1000.127	MICRO	MICRO	MICRO	MIKRO	MICRO
111	430.070	RONDELLA	WASHER	RONDELLE	UNTERLEGSSCHEIBE	ARANDELA
112	430.072	VITE	SCREW	VIS	SCHRAUBE	TORNILLO
113	710.113	PORTAGOMMA	HOSE FITTING	EMBOUT POUR DURITE	GUMMITRÄGER	PORTAMANGUERA
114	710.114	SUPPORTO	SUPPORT	SUPPORT	STÜTZE	SOPORTE
115	710.115	RACCORDO	JOINT	RACCORDEMENT	FERBINDE	EMPALME
116	1000.187	FASCETTA	HOSE COLLORS	BANDE DE SERRAGE	SHELLE	BANDA
117	710.117	TUBO GOMMA	RUBBER TUBE	TUYAU CAOUTCHOUC	GUMMISCHLAUCH	TUBO GOMA
118	400.160.1	RUBINETTO	WATER TAP	ROBINET	HAHN	GRIFO
119	400.161	DADO	NUT	ECROU	MUTTER	TUERCA
120	710.120	TUBO GOMMA	RUBBER TUBE	TUYAU CAOUTCHOUC	GUMMISCHLAUCH	TUBO GOMA
121	710.121	TUBO GOMMA	RUBBER TUBE	TUYAU CAOUTCHOUC	GUMMISCHLAUCH	TUBO GOMA
122	810.122	PIASTRA	PLATE	PLAQUE	PLATTE	PLACA

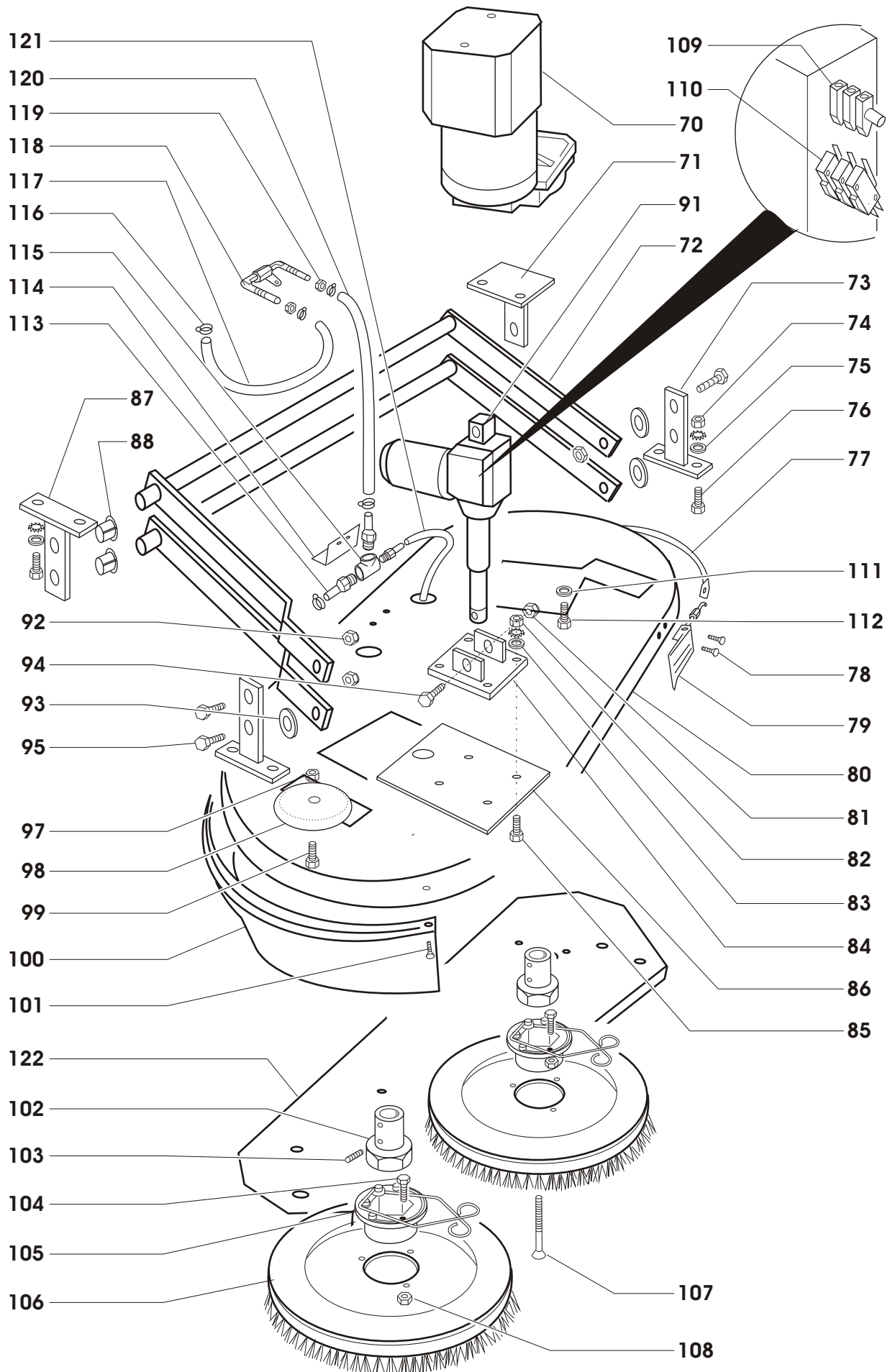



Pos.	Cod. n°	Descrizione	Description	Designation	Benennung	Denominacion
130	700.124	DADO	NUT	ECROU	MUTTER	TUERCA
131	710.131	SUPPORTO	SUPPORT	SUPPORT	STÜTZE	SOPORTE
132	710.028	RONDELLA	WASHER	RONDELLE	UNTERLEGSSCHEIBE	ARANDELA
133	850.058	DADO	NUT	ECROU	MUTTER	TUERCA
134	710.134	SUPPORTO	SUPPORT	SUPPORT	STÜTZE	SOPORTE
135	710.135	VITE	SCREW	VIS	SCHRAUBE	TORNILLO
136	710.088	BOCCOLA	BUSHING	DOUILLE	BÜCHSE	BUJE
137	710.137	LEVA	LEVER	LEVIER	HEBEL	PALANCA
138	850.078	MOLLA	SPRING	RESSORT	FEDER	RESORTE
139	1000.101	PISTONE	PISTON	PISTON	KOLBEN	PISTON
140	710.041	VITE	SCREW	VIS	SCHRAUBE	TORNILLO
141	430.118	RONDELLA	WASHER	RONDELLE	UNTERLEGSSCHEIBE	ARANDELA
142						
143	430.115	PERNO	PIN	GOUJON	BOLZEN	PERNO
144	710.144	DISTANZIALE	SPACER	ENTRETOISE	DISTANZSTÜCK	SEPARADOR
145	710.145	LEVA	LEVER	LEVIER	HEBEL	PALANCA
146	430.182	DADO	NUT	ECROU	MUTTER	TUERCA
147	500.209	POMOLO	KNOB	POIGNEE	GRIFF	PUNO
148	710.148	TUBO	PIPE	TUYAU	ROHR	TUBO
149	500.223.1	POMOLO	KNOB	POIGNEE	GRIFF	PUNO
150	700.046	SUPPORTO	SUPPORT	SUPPORT	STÜTZE	SOPORTE
151	700.042	RONDELLA NYLON	NYLON WASHER	RONDELLE EN NYLON	NYLON UNTERLEGSSCHEIBE	ARANDELA NYLON
152	710.040	RONDELLA	WASHER	RONDELLE	UNTERLEGSSCHEIBE	ARANDELA
153	500.226	FASCETTA	HOSE COLLORS	BANDE DE SERRAGE	SHELLE	BANDA
154	710.154	DISTANZIALE	SPACER	ENTRETOISE	DISTANZSTÜCK	SEPARADOR
155	1000.102	FERMO	STOP	ARRET	ANSCHLAG	TOPE
156	430.176	VITE	SCREW	VIS	SCHRAUBE	TORNILLO
157	860.061	VITE	SCREW	VIS	SCHRAUBE	TORNILLO
158	500.023	RUOTA PARACOLPI	BUFFER WHEEL	ROUE - BUTEE	PRELLRAD	RUEDA GUARDACHOQUES
159	430.176	VITE	SCREW	VIS	SCHRAUBE	TORNILLO
160	710.160	RONDELLA	WASHER	RONDELLE	UNTERLEGSSCHEIBE	ARANDELA
161	850.317	DADO	NUT	ECROU	MUTTER	TUERCA
162	850.265	COPIGLIA	SPLIT PIN	GOUPILLE	SPLINT	CHAVETA
163	430.182	DADO	NUT	ECROU	MUTTER	TUERCA
164	500.222.1	REGOLATORE	REGULATOR	REGULATEUR	REGLER	REGULADOR
165	710.165	VITE	SCREW	VIS	SCHRAUBE	TORNILLO
166	710.166	RONDELLA	WASHER	RONDELLE	UNTERLEGSSCHEIBE	ARANDELA
167	430.176	VITE	SCREW	VIS	SCHRAUBE	TORNILLO
168	710.168	VITE	SCREW	VIS	SCHRAUBE	TORNILLO
169	650.181	LISTA POSTERIORE	BACK STRIP	BARRE POSTERIEUR	HINTER LEISTE	TOPE TRASERO
170	650.180	GOMMA PARA (*)	CREPE RUBBER	CAOUTCHOUC CREPE	PARA GUMMI	GOMA PARA
171	650.209	GOMMA PARA (*)	CREPE RUBBER	CAOUTCHOUC CREPE	PARA GUMMI	GOMA PARA
172	650.208	TERGIPAVIMENTO CORPO	FLOOR WASHING BODY	CORPS - NETTOYAGE	KOERPER - FUSSBODENWISCHER	CUERPO BOQUILLA
173	650.179	GOMMA(*)	RUBBER	CAOUTCHOUC	GUMMI	GOMA
174	650.178	LISTA ANTERIORE	FRONT STREEP	BARRE AVANT	VORDERE LEISTE	TOPE ANTERIOR
175	710.175	SUPPORTO	SUPPORT	SUPPORT	STÜTZE	SOPORTE
176	710.176	VITE	SCREW	VIS	SCHRAUBE	TORNILLO
177	710.177	RUOTA	WHEEL	ROUE	RAD	RUEDA
178	710.178	DISTANZIALE	SPACER	ENTRETOISE	DISTANZSTÜCK	SEPARADOR
179	430.311	DADO	NUT	ECROU	MUTTER	TUERCA
180	710.180	DISTANZIALE	SPACER	ENTRETOISE	DISTANZSTÜCK	SEPARADOR
181	850.280	PERNO	PIN	GOUJON	BOLZEN	PERNO
182	710.091	ATTUATORE	ACTUATOR	ACTUATEUR	ANTRIEB	ACTIVADOR
183	810.183	SUPPORTO	SUPPORT	SUPPORT	STÜTZE	SOPORTE
184	850.310	DADO	NUT	ECROU	MUTTER	TUERCA
185	700.124	DADO	NUT	ECROU	MUTTER	TUERCA
186	430.176	VITE	SCREW	VIS	SCHRAUBE	TORNILLO
187	701.104	RONDELLA	WASHER	RONDELLE	UNTERLEGSSCHEIBE	ARANDELA
188	430.176	VITE	SCREW	VIS	SCHRAUBE	TORNILLO
189	810.189	CATENA	CHAIN	CHAÎNE	KETTE	CADENA
190	1000.123	FERMO	STOP	ARRET	ANSCHLAG	TOPE

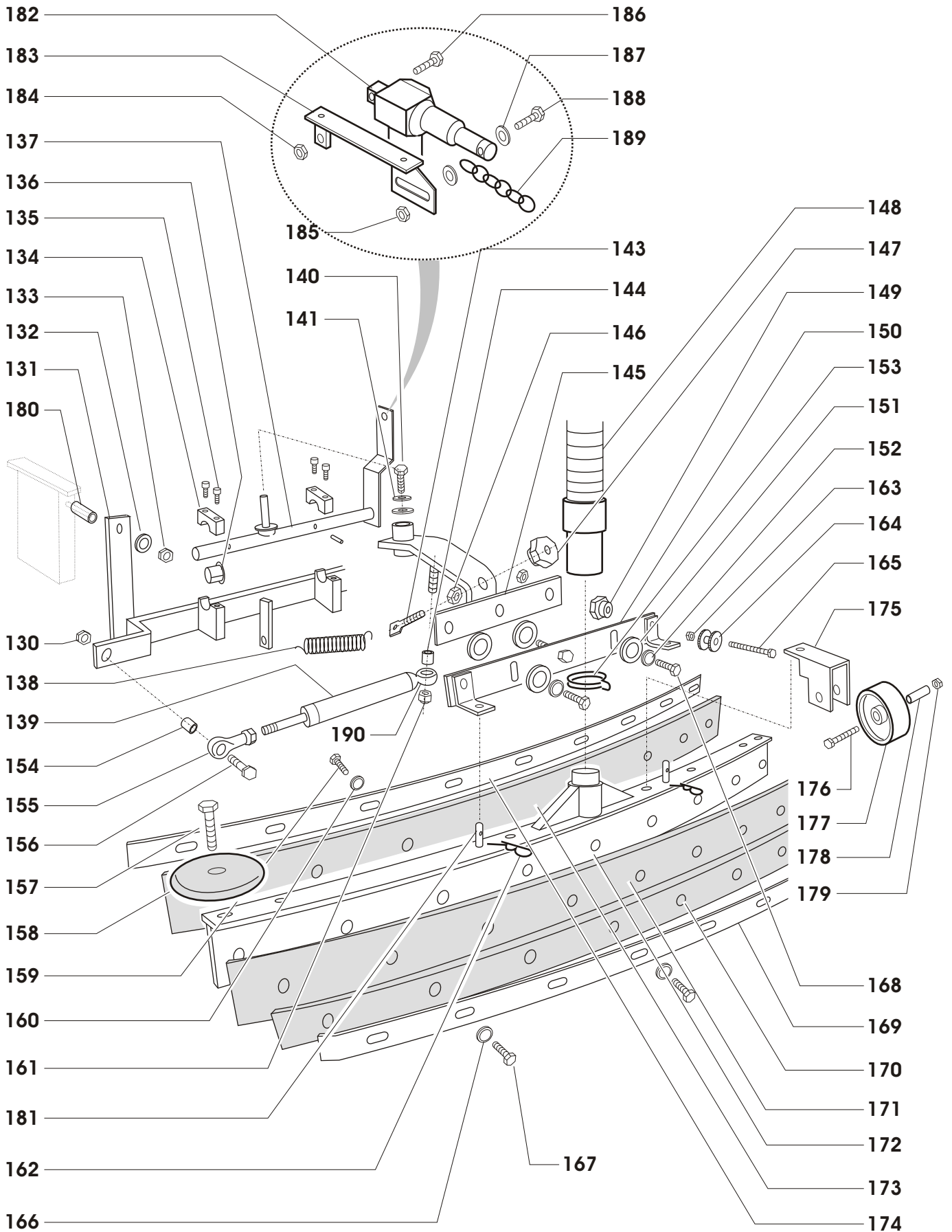



Pos.	Cod. n°	Descrizione	Description	Designation	Benennung	Denominacion
200	710.200	COPERTURA	CHEST	COFFRE	HAUBE	COFRE
201	710.201	ASTA	ROD	TIGE	STANGE	BARRA
202	500.061	POMOLO	KNOB	POIGNEE	GRIFF	PUNO
203	1000.072	ALBERO	SHAFT	ARBRE	WELLE	EJE
204	1000.069	LINGUETTA	TANG	LANGUETTE	FEDERKEIL	LANGUETA
205	1000.068	VOLANTE	STEERING WHEEL	VOLANT	LENKRAD	VOLANTE
206						
207			COMPLETE CABLE		KABEL VOLLSTANDIG	
208	710.208	SERBATOIO	TANK	RESERVOIR	BEHAELTER	TANQUE
209	1000.196	SEDILE	SEAT	SIEGE	SITZ	ASIENTO
210	1000.194	TAPPO	PLUG	BOUCHON	VERSCHLUSS	TAPON
211	710.211	GANCIO	HOOK	CROCHET	HAKEN	GANCHO
212	710.212	SUPPORTO	SUPPORT	SUPPORT	STÜTZE	SOPORTE
213	710.213	PROTEZIONE	SHIELD	PROTECTION	ABDECKUNG	DEFENSA
214	710.214	CARTER	CASING	CARTER	GEHÄUSE	CARTER
215	710.215	ALBERO	SHAFT	ARBRE	WELLE	EJE
216	1000.110	LINGUETTA	TANG	LANGUETTE	FEDERKEIL	LANGUETA
217	710.217	PIGNONE	PINION	PIGNON	RITZEL	PINON
218	710.218	CLACSON	HORN	AVERTISSEURCAUSTQUE	HUPE	BOCINA
219	710.219	CATENA	CHAIN	CHAINE	KETTE	CADENA
220	1000.001	LEVA FRENO	BRAKE LEVER	FREIN LEVIER	BREMSE - HEBEL	PALANCA FRENO
221	710.221	CAVO COMPLETO	COMPLETE CABLE	FIL COMPLETE	KABEL VOLLSTANDIG	CABLE COMPLETO
222	710.222	PEDANA 1	FLOOR PLATE 1	PLANCHER 1	BODENBLECH 1	SUELO 1
223	710.223	PEDANA 2	FLOOR PLATE 2	PLANCHER 2	BODENBLECH 2	SUELO 2
224	500.089	RUBINETTO	COCK	ROBINET	HAHN	GRIFO
225	500.084.1	FLANGIA MOBILE	MOVABLE FLANGE	BRIDE MOBILE	BEWEGLICHER FLANSCH	BRIDA MOVIL
226	500.087.1	POMOLO	KNOB	POIGNEE	GRIFF	PUNO
227	500.085	RONDELLA	WASHER	RONDELLE	UNTERLEGSSCHEIBE	ARANDELA
228	500.083.1	GUARNIZIONE	SEAL	JOINT	DICHTUNG	JUNTA
229	500.079.1	FLANGIA FISSA	FIXED FLANGE	BRIDE FIXE	FESTER FLANSCH	BRIDA FIJO
230	500.078	GUARNIZIONE	SEAL	JOINT	DICHTUNG	JUNTA
231	1000.184	DADO	NUT	ECROU	MUTTER	TUERCA
232	1000.183	RONDELLA	WASHER	RONDELLE	UNTERLEGSSCHEIBE	ARANDELA
233	500.044	FILTRO	FILTER	FILTRE	FILTER	FILTRO
234	710.234	VITE	SCREW	VIS	SCHRAUBE	TORNILLO
235	710.235	VITE	SCREW	VIS	SCHRAUBE	TORNILLO
236	710.236	CARTER	CASING	CARTER	GEHÄUSE	CARTER
237	710.237	CARRUCOLA	SHEAVE	POULIE	LAUFROLLE	GARRUCHA
238	1000.196.2	PIASTRA	PLATE	PLAQUE	PLATTE	PLACA
239	710.239	GIUNTO	COUPLING	JOINT	KUPPLUNG	EMPALME
240	710.240	COPERCHIO	COVER	COUVERCLE	DECKEL	TAPA
241	710.241	LAMPEGGIANTE	LAMP	LAMPE	LAMPE	LAMPARA
242	710.242	SUPPORTO	SUPPORT	SUPPORT	STÜTZE	SOPORTE
243	430.318	MICRO	MICRO	MICRO	MIKRO	MICRO

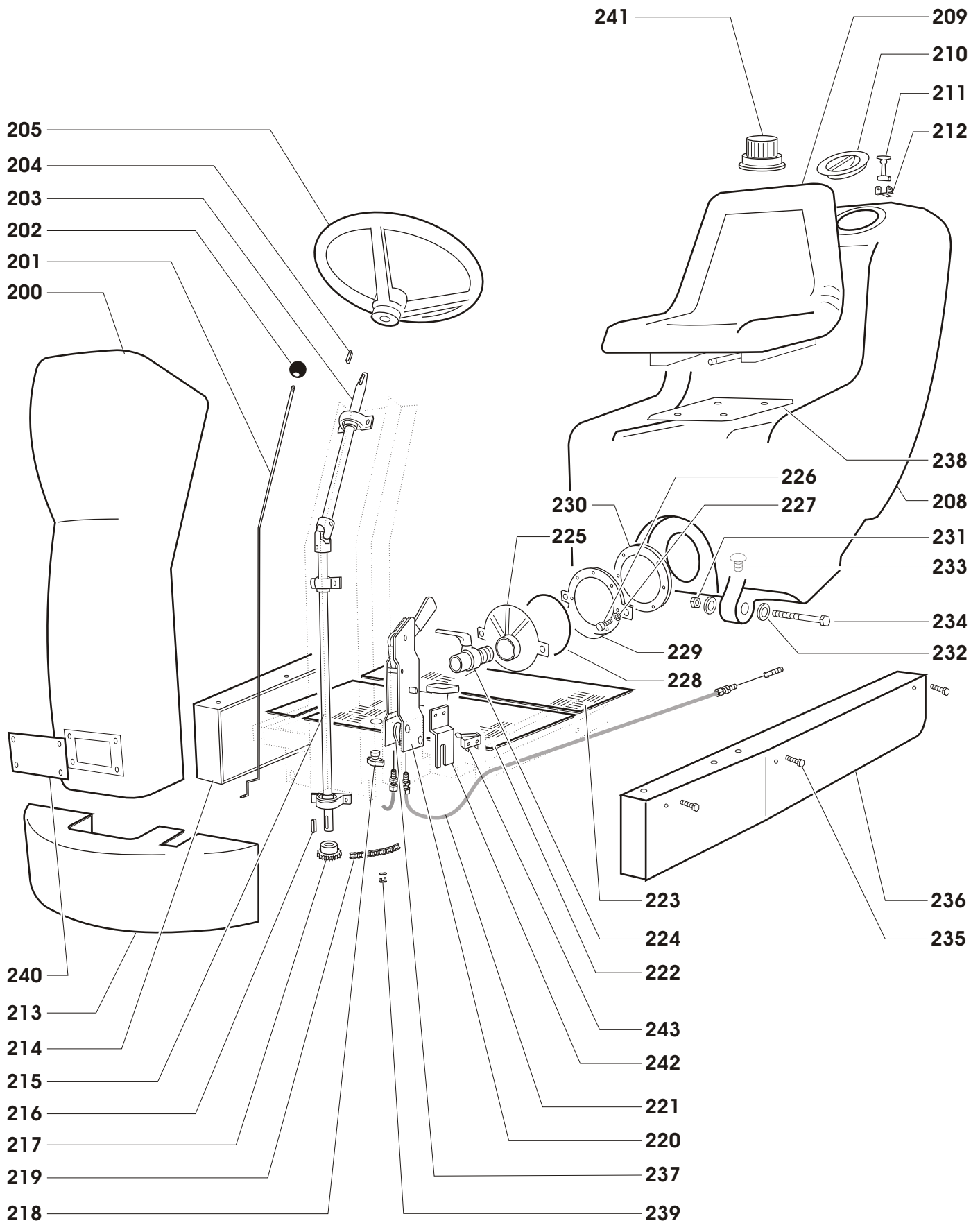



Pos.	Cod. n°	Descrizione	Description	Designation	Benennung	Denominacion
250	400.040	ANELLO DI FERMO	LOCK RING	BAGUE D'ARRET	SICHERUNGSRING	ANILLO DE FIJACION
251	500.257	MOTORE ASPIRAZIONE	SUCTION MOTOR	MOTEUR DE ASPIRATION	SAUGMOTOR	MOTOR DE ASPIRACION
252	500.067	GUARNIZIONE	SEAL	JOINT	DICHTUNG	JUNTA
253	500.070	RETE	NET	GRILLE	GITTER	RED
254	500.069	SPUGNA	SPONGE	EPONGE	SCHWAMM	EPONJA
255	500.068	SUPPORTO	SUPPORT	SUPPORT	STÜTZE	SOPORTE
256	500.067	GUARNIZIONE	SEAL	JOINT	DICHTUNG	JUNTA
257	410.032	VITE	SCREW	VIS	SCHRAUBE	TORNILLO
258	710.258	SUPPORTO	SUPPORT	SUPPORT	STÜTZE	SOPORTE
259	710.259	TUBO	PIPE	TUYAU	ROHR	TUBO
260	410.105.1	TIRANTE	TIE ROD	TIRANT	ZUGSTANGE	TIRANTE
261	710.261	TUBO	PIPE	TUYAU	ROHR	TUBO
262	510.118	PIASTRINA	PLATE	PLAQUE	PLATTE	PLACA
263	710.263	VITE	SCREW	VIS	SCHRAUBE	TORNILLO
264	710.264	ASTA	ROD	TIGE	STANGE	BARRA
265	510.116	PIASTRINA	PLATE	PLAQUE	PLATTE	PLACA
266	710.266	SERBATOIO	TANK	RESERVOIR	BEHAELTER	TANQUE
267	1000.279	CURVA	CURVE	ARRONDI	KRUMMER	CURVA
268	400.021	FERMA TUBO	PIPE STRAPP	SERRE - TUBE	ROHRHALTER	SUJETATUBO
269	710.269	TUBO	PIPE	TUYAU	ROHR	TUBO
270	710.270	FASCETTA	HOSE COLLORS	BANDE DE SERRAGE	SHELLE	BANDA
271	500.089.1	PORTAGOMMA	HOSE FITTING	EMBOUT POUR DURITE	GUMMITRÄGER	PORTAMANGUERA
272	500.084.1	FLANGIA MOBILE	MOVABLE FLANGE	BRIDE MOBILE	BEWEGLICHER FLANSCH	BRIDA MOVIL
273	500.083.1	GUARNIZIONE	SEAL	JOINT	DICHTUNG	JUNTA
274	500.085	RONDELLA	WASHER	RONDELLE	UNTERLEGSSCHEIBE	ARANDELA
275	500.087.1	POMOLO	KNOB	POIGNEE	GRIFF	PUNO
276	500.078	GUARNIZIONE	SEAL	JOINT	DICHTUNG	JUNTA
277	500.079.1	FLANGIA FISSA	FIXED FLANGE	BRIDE FIXE	FESTER FLANSCH	BRIDA FIJO
278	501.160	MANICOTTO	SLEEVE	MANCHON	HÜLSE	MANGUITO
279	500.094	GALLEGGIANTE	FLOAT LEVEL	MOUCHARD	SCHWIMMER	FLOTADOR NIVEL
(*)	500.099	GALLEGGIANTE COMPLETO	COMPLETE FLOAT LEVEL	FLOTTEUR COMPLETE	SCHWIMMER - VOLLSTÄNDIG	FLOTADOR NIVEL COMPLETO
280	400.031	TAPPO	PLUG	BOUCHON	VERSCHLUSS	TAPON

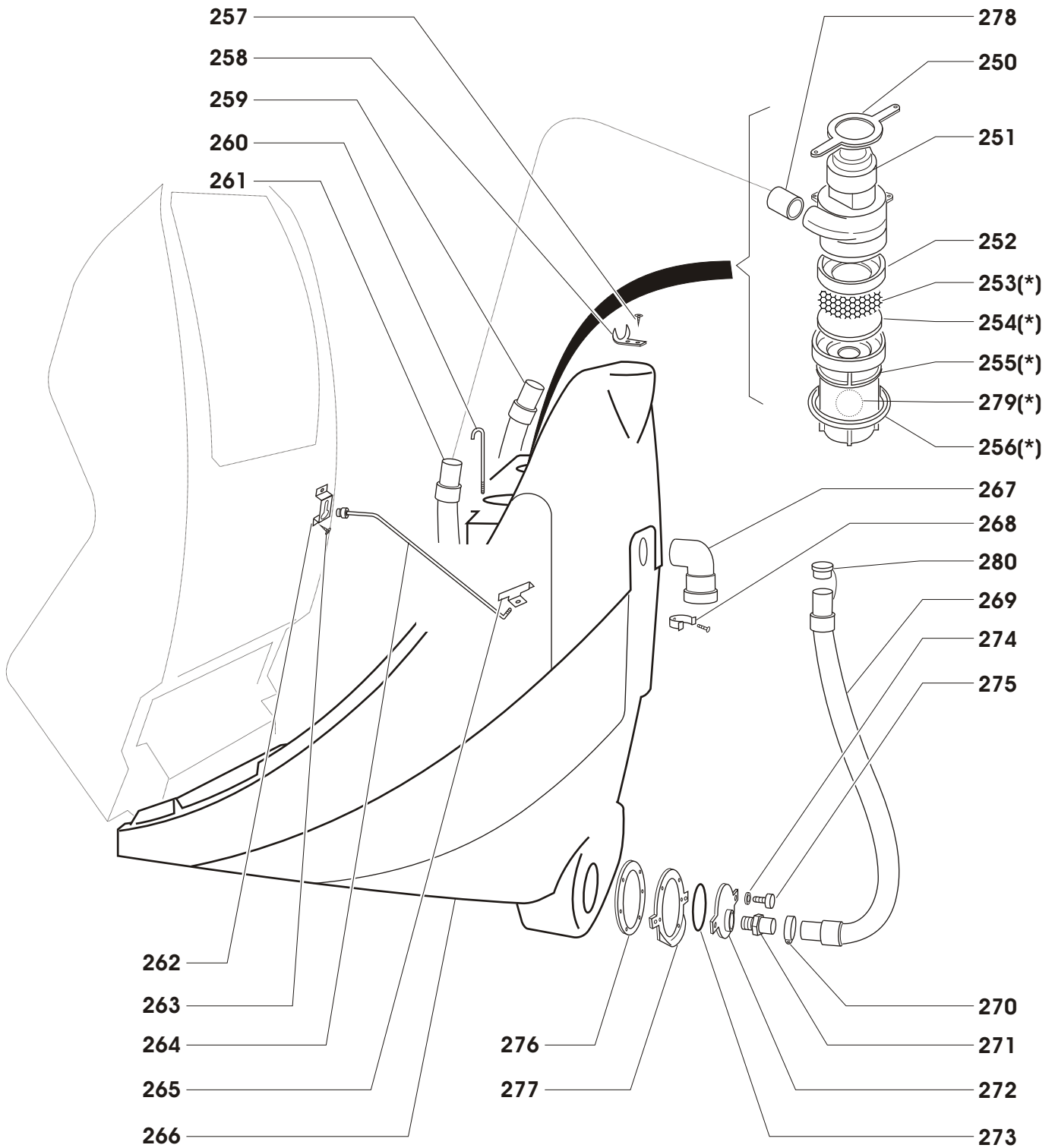



Pos.	Cod. n°	Descrizione	Description	Designation	Benennung	Denominacion
300	1000.293	VITE	SCREW	VIS	SCHRAUBE	TORNILLO
301	710.301	SCHEDA MARTINETTO	JACK CARD	CARTE CRIC	SCHRAUBENWINDE - KARTE	FICHA MARTINETTE
302	710.302	SCHEDA TRAZIONE	TRACTION CARD	CARTE TRACTION	NABENANTRIEB - KARTE	FICHA TRACCION
303	710.303	PIASTRA	PLATE	PLAQUE	PLATTE	PLACA
304	430.293	TELERUTTORE	REMOTE CONTROL	TELERUPTEUR	FERNSCHALTER	TELEINTERRUPTOR
305	860.230	PORTAFUSIBILE	FUSE HOLDER	PORTE FUSIBLE	SICHERUNGSHALTER	PORTAFUSIBLES
306	1000.288	SLITTA	SLIDE	COULISSE	SCHLITTEN	CORREDERA
307	1000.301	DADO	NUT	ECROU	MUTTER	TUERCA
308	1000.302	RONDELLA	WASHER	RONDELLE	UNTERLEGSSCHEIBE	ARANDELA
310	710.310	CLACSON	HORN	CLAXON	HUPE	AVISADOR ACUSTICO
311	700.231	FUSIBILE	FUSE	FUSIBLE	SICHERUNG	FUSIBLE
312	700.231	FUSIBILE	FUSE	FUSIBLE	SICHERUNG	FUSIBLE
313	1000.344	FUSIBILE	FUSE	FUSIBLE	SICHERUNG	FUSIBLE
314	1000.323	POTENZIOMETRO	POTENTIOMETER	POTENTIOMETRE	POTENTIOMETER	POTENCIOMETRO
315	710.315	LIVELLO CARICA BATTERIE	BATTERY CHARGE LEVEL	RIVEAU DE CHARGES DES BATTERIES	BATERIELEISTUNG ABGELESEN WERDEN	NIVEL DE CARGA DE LAS BATERIAS
316	710.316	PULSANTE	PUSH BUTTON	BOUTON	DRUCKKNOPF	PULSANTE
317	710.317	PANNELLO ELETTRICO	ELECTRIC PANEL	PANNEAU ELECTRIQUE	FAHRELEKTRIC	PANEL ELECTRICO
318	850.472	POTENZIOMETRO	POTENTIOMETER	POTENTIOMETRE	POTENTIOMETER	POTENCIOMETRO
319	1000.334	SPIA LUMINOSA	PILOT LIGHT	LAMPE TEMOIN	KONTROLLAMPE	LAMPARA PILOTO
320	430.302	INTERRUTTORE	SWITCH	INTERRUPTEUR	SCHALTER	INTERRUPTOR
321	850.416	INTERRUTTORE A CHIAVE	KEY SWITCH	INTERRUPTEUR A CLE	SCLUSSEL - SCHALTER	INTERRUPTOR LLAVE
322	710.322	INTERRUTTORE	SWITCH	INTERRUPTEUR	SCHALTER	INTERRUPTOR
323	1000.296.1	BLOCCO	BLOCK	BLOC	BLOCK	BLOQUEO
324	710.324	SPINA	PIN	GOUPILLE	STIFT	PASADOR
325	1000.300	VITE	SCREW	VIS	SCHRAUBE	TORNILLO
326	710.326	CAVO -	CABLE -	FIL -	KABEL -	CABLE -
327	1000.338	CAVO	CABLE	FIL	KABEL	CABLE
328	710.328	CAVO +	CABLE +	FIL +	KABEL +	CABLE +
329	710.329	FUSIBILE	FUSE	FUSIBLE	SICHERUNG	FUSIBLE
330	710.330	BATTERIA TUBOLARE 425 Ah	HOSE BATTERY 425 Ah	BATTERIE - TUYAU 425 Ah	ROHR - BATTERIE 425 Ah	BATERIA MANGUERA 425 Ah
331	1000.296	MANIGLIA	HANDLE	POIGNEE	GRIFF	ASIDERO
334	710.334	SCHEDA DIODI	DIODE CARD	CARTE	KARTE	FICHA
335	710.335	PIASTRINA	PLATE	PLAQUE	PLATTE	PLACA
(*)	710.332	IMPIANTO ELETTRICO	ELECTRIC PLANT	INSTALLATION ELECTRIQUE	ELEKTROANLAGE	EQUIPO ELECTRICO
(°)	710.333	IMPIANTO CRUSCOTTO	PANEL PLANT	INSTALLATION PANNEAU	PANEELANLAGE	EQUIPO PANEL
336	710.336	PIASTRINA	PLATE	PLAQUE	PLATTE	PLACA

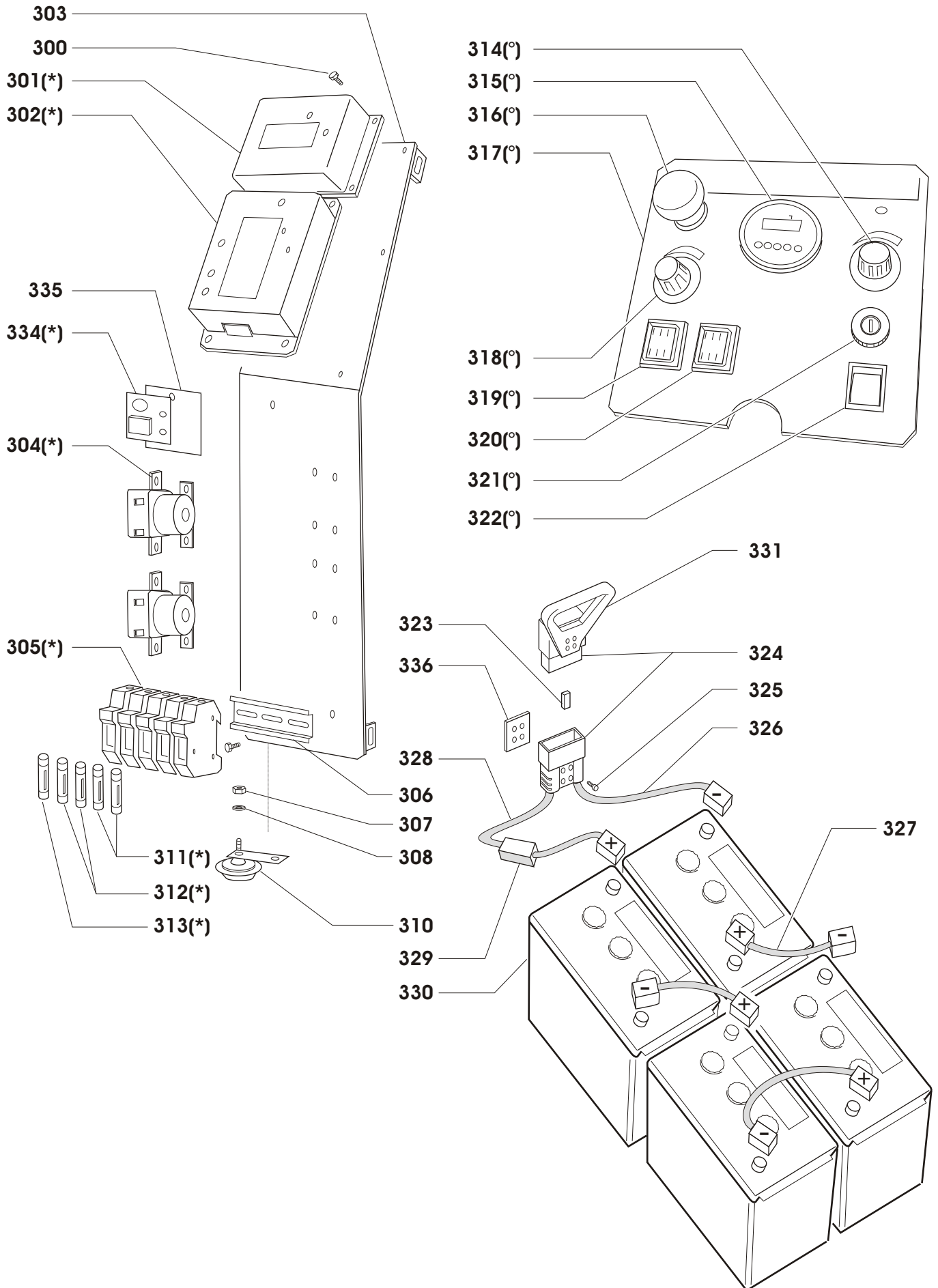

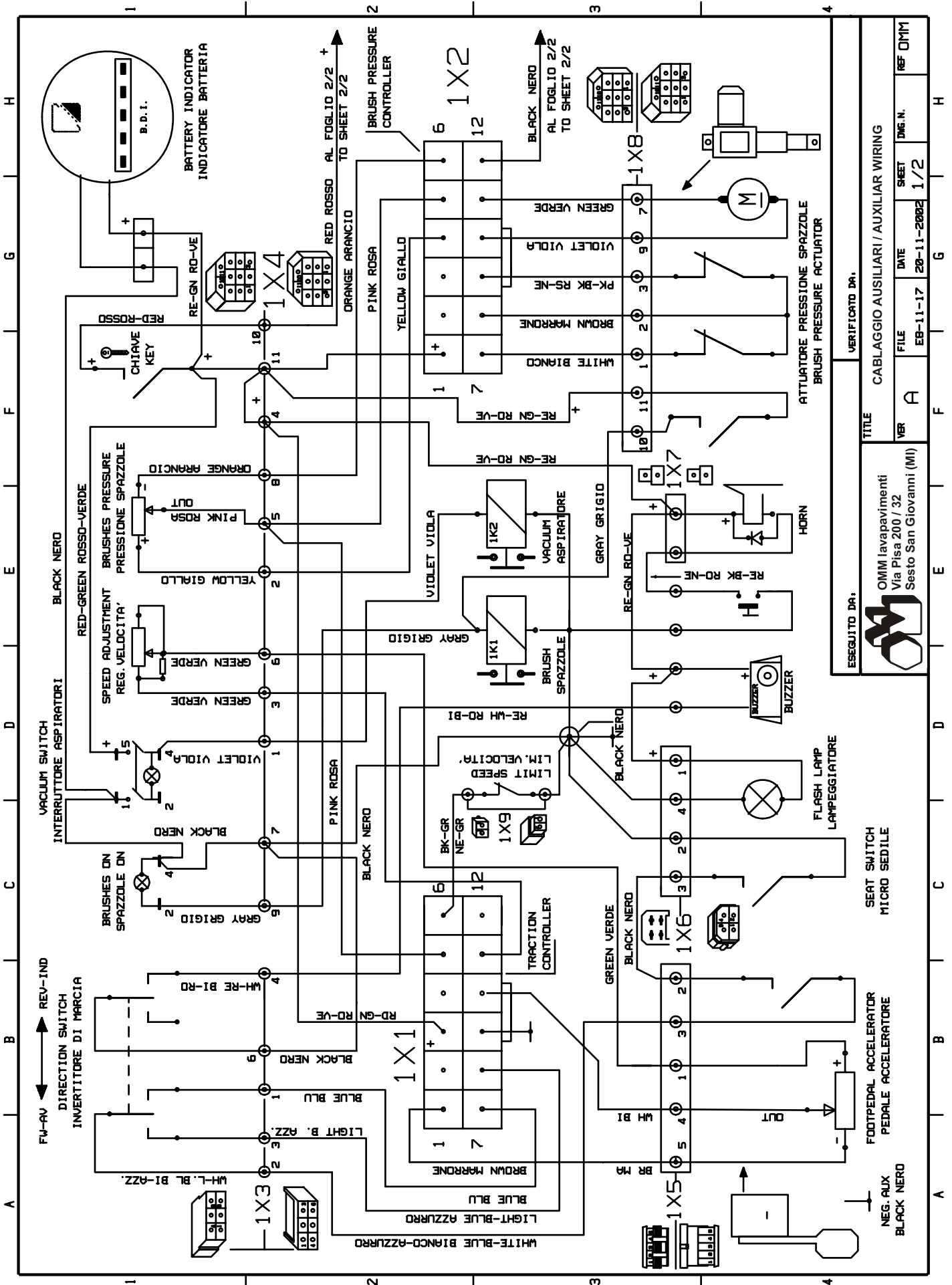

ESEGUITO DA:		VERIFICATO DA:	
TITLE CABLAGGIO AUSILIARI / AUXILIAR WIRING			
VER	FILE	DATE	SHEET
A	A	EB-11-17	1/2
OMM Iavapavimenti Via Pisa 200 / 32 Sesto San Giovanni (MI)		ING.N. REF OMM	

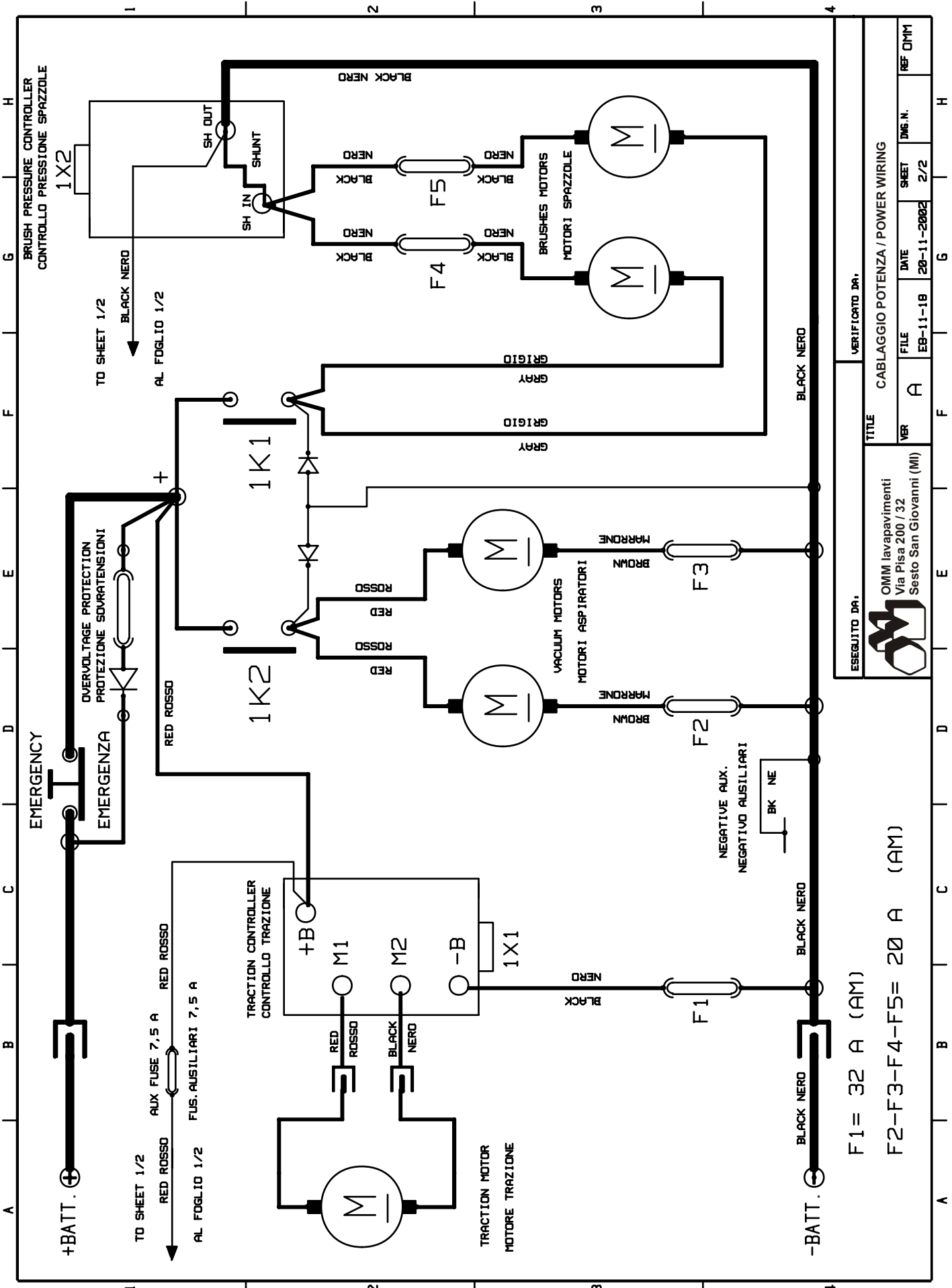

F1 = 32 A (AM)
 F2-F3-F4-F5 = 20 A (AM)

ESEGUITO DA:		VERIFICATO DA:	
TITLE CABLAGGIO POTENZA / POWER WIRING OMM Iavapavimenti Via Pisa 200 / 32 Sesto San Giovanni (MI)			
VER	FILE	DATE	SHEET
A	A	EB-11-18	2/2
REF OMM		DISE.N.	



**DICHIARAZIONE-DECLARATION-DECLARATION-ERKLÄRUNG
DECLARACION**

**DICHIARAZIONE DI CONFORMITÀ: la
DECLARATION OF CONFORMITY: (company name)
DECLARATION DE CONFORMITE: la
ÜBEREINSTIMMUNGSERKLÄRUNG
DECLARACION DE CONFORMIDAD**

**OMM lavapavimenti Via Cantu' 8/10
Cinisello Balsamo (MI) - ITALY
Tel. ++39.02.612.83.80 - Fax ++39.02.66.59.49.00**

dichiara sotto la propria esclusiva responsabilità che la/le macchina/e nuova/e:
declares under its own responsibility that the new machine/s:
déclare sous sa responsabilité exclusivement que le/les machine/s nouveau/s:
erklärt unter ausschließlicher eigener Verantwortung, daß die Maschine(n) neu:
declara bajo su propia y exclusiva responsabilidad que la/s máquina/s nueva/s:



800 Stile

Modello/model/modele/modell/modelo

Matricola /serial number/numero matricule
seriennummer/numero matricula

Anno/year/année/jahr/ano

è/sono conforme/mi alle seguenti norme:
conform/s to the following laws:
est/sont conforme/saux normes:
mit den folgenden Normen übereinstimmen:
está/están conforme/s a lassiguientes normas:

EN55014/94 - EN60555-2-3/82 - EN50082-1/92 - EN60335/2/.... - VDE0700T205

ed inoltre è/sono fabbricata/e nel rispetto delle direttive e/o decreti:
and moreover is/are built according to the directives and/or decrees:
et est/sont fabriquées, en outre, conformément aux directives et/ou décrets:
und daß sie unter Einhaltung folgender Verordnungen und/oder Dekrete hergestellt worden (sind):
y que además ha/han sido fabricada/s en conformidad con las directivas y/o decretos:

89/336/CEE - 73/23/CEE - 98/37/CEE - DPR547 - DPR224

l'amministratore:	CLAUDIO MESCOLI	Firma	Data
executive officer:	CLAUDIO MESCOLI	Signed	Date
l'administrateur:	CLAUDIO MESCOLI	Signature	Date
der Geschäftsführer:	CLAUDIO MESCOLI	Firma	Datum
el administrador:	CLAUDIO MESCOLI	Firma	Fecha