

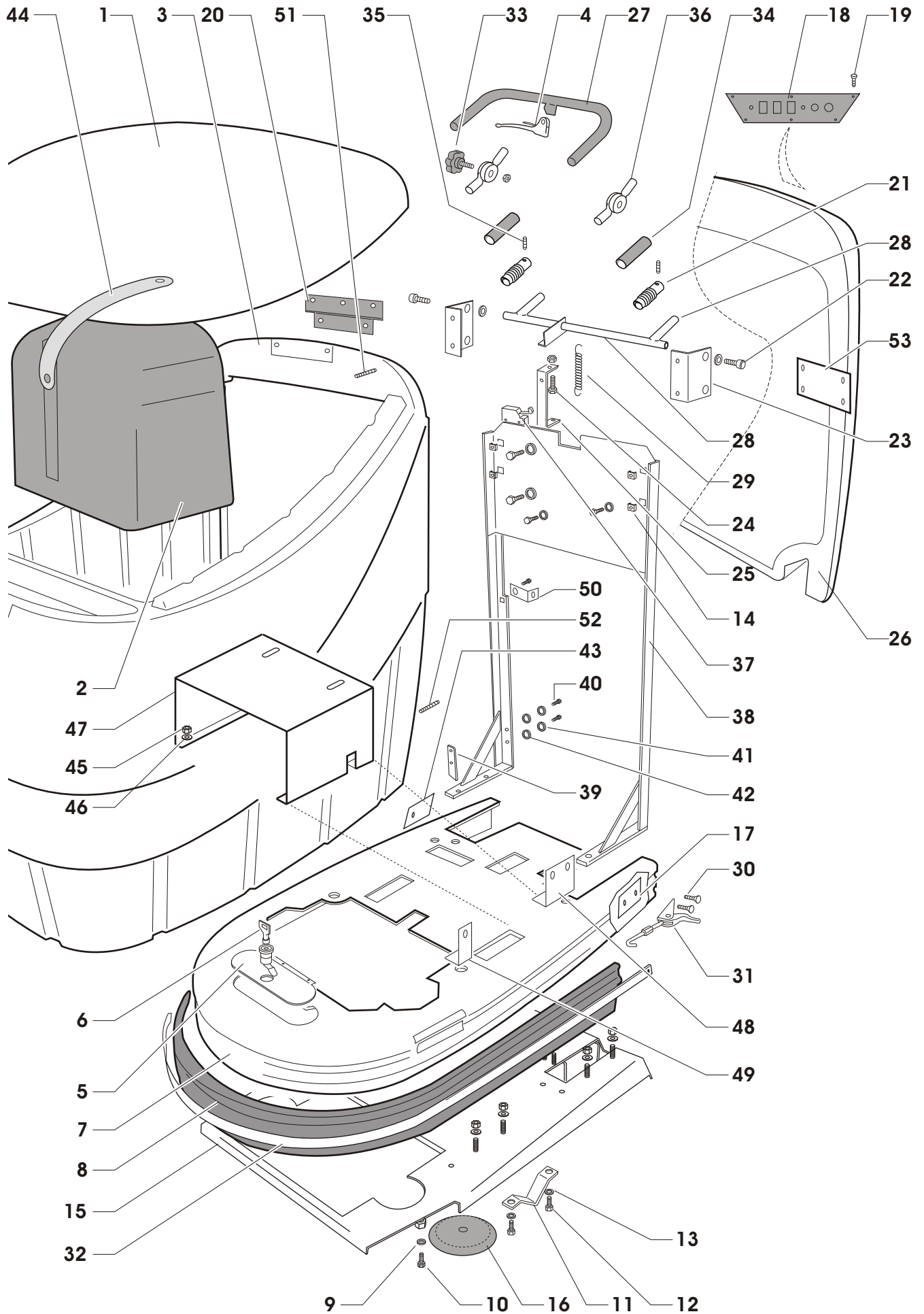

Pos.	Cod. n°	Descrizione	Description	Designation	Benennung	Denominacion
1	510.001	COPERCHIO	COVER	COUVERCLE	DECKEL	TAPA
2	510.002	COPERCHIO MOTORE	SUCTION MOTOR COVER	COUVERCLE MOTEUR ASPIRATION	DECKEL SAUGMOTOR	TAPA MOTOR DE ASPIRACION
3	510.003	CARENATURA	CHEST	COFFRE	HAUBE	COFRE
4	501.004	LEVA FRENO	BRAKE LEVER	FREIN LEVIER	BREMSE - HEBEL	PALANCA FRENO
5	501.005	COPERCHIO	COVER	COUVERCLE	DECKEL	TAPA
6	501.006	CHIAVE	KEY	CLE	SCHLUSSEL	LLAVE
7	510.007	CARENATURA	CHEST	COFFRE	HAUBE	COFRE
8	850.305	PARASPRUZZI	SPLASH GUARD	ECRAN ANTI - ECLABOUSSURES	SPRITZBLECH	FALDOM
9	430.015	RONDELLA	WASHER	RONDELLE	UNTERLEGSSCHEIBE	ARANDELA
10	430.016	VITE	SCREW	VIS	SCHRAUBE	TORNILLO
11	510.011	STAFFA	YOKE	ETRIER	SPANNEISEN	ESTRIBO
12	430.120	VITE	SCREW	VIS	SCHRAUBE	TORNILLO
13	430.118	RONDELLA	WASHER	RONDELLE	UNTERLEGSSCHEIBE	ARANDELA
14	430.063	DADO GABBIA	CAGE NUT	ECROU A CAGE	MUTTERKAEFIG	TUERCA A JAULA
15	510.015	TELAIO	FRAME	CHASSIS	RAHMEN	BASTIDOR
16	500.023	RUOTA PARACOLPI	BUFFER WHEEL	ROUE - BUTEE	PRELLRAD	RUEDA GUARDACHOQUES
17	510.017	PIASTRINA	PLATE	PLAQUETTE	PLAETTCHEN	CHAPITA
18	510.018	PANNELLO COMANDI	CONTROL PANEL	PANNEAU DU COMMANDE	SCHALT Tafel	PANEL DE MANDO
19	410.008	VITE	SCREW	VIS	SCHRAUBE	TORNILLO
20	510.020	CERNIERA	HINGE	CHARNIERE	SCHARNIER	BISAGRA
21	501.024	SOFFIETTO	BELLOWS	SOUFFLET	GEBLASE-	FUELLE
22	430.120	VITE	SCREW	VIS	SCHRAUBE	TORNILLO
23	501.033	SQUADRETTA	SQUARE	EQUERRE	WINKEL	ESCUADRETA
24	501.027	VITE	SCREW	VIS	SCHRAUBE	TORNILLO
25	501.028.1	SUPPORTO	SUPPORT	SUPPORT	STÜTZE	SOPORTE
26	510.026	CRUSCOTTO	PANEL	PANNEAU	PANEEL	PANEL
27	430.323.1	MANICO	HANDLE	MANCHE	GRIFF	MANGO
28	510.028	LEVA	LEVER	LEVIER	HEBEL	PALANCA
29	500.141	MOLLA	SPRING	RESSORT	FEDER	RESORTE
30	501.047	VITE	SCREW	VIS	SCHRAUBE	TORNILLO
31	501.048	GANCIO	HOOK	CROCHET	HAKEN	GANCHO
32	850.308	LISTA DI FERMO	STOP STRIP	BARRE D'ARRET	SPARRLEISTE	TOPE
33	400.149	POMOLO	KNOB	POIGNEE	GRIFF	PUNO
34	501.054	MANICO FINALE	HANDLE	MANCHE	GRIFF	MANGO
35	430.160	GRANO	DOWEL	GOUJON	ZAPFEN	GRANO
36	501.055	SNODO FORATO	ARTICULATION	ARTICULATION	GELENK	ARTICULACION
37	430.318	MICRO	MICRO	MICRO	MIKRO	MICRO
38	510.038	PANNELLO	PANEL	PANNEAU	PANEEL	PANEL
39	430.108	PIASTRINA	PLATE	PLAQUETTE	PLAETTCHEN	CHAPITA
40	430.107	VITE	SCREW	VIS	SCHRAUBE	TORNILLO
41	430.070	RONDELLA	WASHER	RONDELLE	UNTERLEGSSCHEIBE	ARANDELA
42	430.109	RONDELLA ELASTICA	LOCKWASHER	RONDELLE FREIN	SICHERUNGSRING	ARANDELA DE FRENO
43	510.043	PIASTRINA	PLATE	PLAQUETTE	PLAETTCHEN	CHAPITA
44	510.044	GOMMA COPERCHIO	COVER RUBBER	COUVERCLE CAOUTCHOUC	DECKEL PARAGUMMI	GOMA PARA TAPA
45	430.182	DADO	NUT	ECROU	MUTTER	TUERCA
46	430.118	RONDELLA	WASHER	RONDELLE	UNTERLEGGSSCHEIBE	ARANDELA
47	510.047	SUPPORTO	SUPPORT	SUPPORT	STÜTZE	SOPORTE
48	510.048	PIASTRINA	PLATE	PLAQUE	PLATTE	PLACA
49	510.049	PIASTRINA	PLATE	PLAQUE	PLATTE	PLACA
50	510.050	PIASTRINA	PLATE	PLAQUE	PLATTE	PLACA
51	510.051	PERNO	PIN	GOUJON	BOLZEN	PERNO
52	510.052	PERNO	PIN	GOUJON	BOLZEN	PERNO
53	510.053	COPERCHIO	COVER	COUVERCLE	BOLZEN	DECKEL





Pos.	Cod. n°	Descrizione	Description	Designation	Benennung	Denominacion
80	500.044	FILTRO	FILTER	FILTRE	FILTER	FILTRO
81	501.088	PORTAGOMMA	HOSE FITTING	EMBOUT POUR DURITE	GUMMITRÄGER	PORTAMANGUERA
82	430.066.B	MOTORIDUTTORE	REDUCER MOTOR	REDUCTEUR-MOTEUR	REDUZIERER-MOTOR	REDUCTOR-MOTOR
83	510.083	PIASTRA	PLATE	PLAQUE	PLATTE	PLACA
84	430.070	RONDELLA	WASHER	RONDELLE	UNTERLEGSSCHEIBE	ARANDELA
85	430.072	VITE	SCREW	VIS	SCHRAUBE	TORNILLO
86	430.069.1	LINGUETTA	TANG	LANGUETTE	FEDERKEIL	LANGUETA
87	430.074.1	GIUNTO	COUPLING	JOINT	KUPPLUNG	EMPALME
88	430.075	VITE	SCREW	VIS	SCHRAUBE	TORNILLO
89	430.076.1	SUPPORTO CON MOLLA	SUPPORT WITH SPRING	SUPPORT AVEC RESSORT	STÜTZEFEDER	SOPORTE RESORTE
90	500.171	SPAZZOLA	BRUSH	BROSSE	BUERSTE	CEPILLO
90	500.171.1	SPAZZOLA TYNEX	TINEX BRUSH	BROSSE EN TINEX	TINEXBURSTE	CEPILLO TINEX
90	500.171.2	SPAZZOLA ACCIAIO	STEEL BRUSH	BROSSE EN ACIER	STAHLBURSTE	CEPILLO ACERO
90	500.171.3	SPAZZOLA VEGETALE	VEGETABLE BRUSH	BROSSE VEGETAL	VEGETAL BURSTE	CEPILLO VEGETAL
90	500.178.3	TRASCINATORE	CONVEYOR	ENTRAINEMENT	MITNEHMER	CINTA DE ARRASTRE
90	500.178.1	DISCO	DISC	DISQUE	SCHEIBE	DISCO
91	430.078	DADO	NUT	ECROU	MUTTER	TUERCA
92	430.079	VITE	SCREW	VIS	SCHRAUBE	TORNILLO
93	500.061	POMOLO	KNOB	POIGNEE	GRIFF	PUNO
94	510.094	ASTA	ROD	TIGE	STANGE	BARRA
95	500.053	RONDELLA	WASHER	RONDELLE	UNTERLEGSSCHEIBE	ARANDELA
96	500.054	DADO	NUT	ECROU	MUTTER	TUERCA
97	500.051	LEVA	LEVER	LEVIER	HEBEL	PALANCA
98	500.056	COPIGLIA	SPLIT PIN	GOUPILLE	SPLINT	CHAVETA
99	400.160.1	RUBINETTO	WATER TAP	ROBINET	HAHN	GRIFO
100	400.161	DADO	NUT	ECROU	MUTTER	TUERCA
101	430.091	FASCETTA	HOSE COLLORS	BANDE DE SERRAGE	SCHELLE	BANDA
102	501.109	TUBO	PIPE	TUYAU	ROHR	TUBO
103	510.103	LEVA	LEVER	LEVIER	HEBEL	PALANCA
104	500.155	RONDELLA NYLON	NYLON WASHER	RONDELLE EN NYLON	NYLON UNTERLEGSSCHEIBE	ARANDELA NYLON
105	430.182	DADO	NUT	ECROU	MUTTER	TUERCA
106	430.118	RONDELLA	WASHER	RONDELLE	UNTERLEGSSCHEIBE	ARANDELA
107	430.119	SUPPORTO	SUPPORT	SUPPORT	STÜTZE	SOPORTE
108	510.108	LEVA	LEVER	LEVIER	HEBEL	PALANCA
109	500.155	RONDELLA NYLON	NYLON WASHER	RONDELLE EN NYLON	NYLON UNTERLEGSSCHEIBE	ARANDELA NYLON
110	430.120	VITE	SCREW	VIS	SCHRAUBE	TORNILLO
111	430.094	SUPPORTO	SUPPORT	SUPPORT	STÜTZE	SOPORTE
112	500.154	COPRIPEDALE	PEDAL COVER	COUVRE PEDALE	PEDALKAPPE	CUBREPEDAL
113	400.087	MOLLA	SPRING	RESSORT	FEDER	RESORTE
114	430.115	PERNO	PIN	GOUJON	BOLZEN	PERNO
115	430.182	DADO	NUT	ECROU	MUTTER	TUERCA
116	510.116	PIASTRINA	PLATE	PLAQUE	PLATTE	PLACA
117	510.117	ASTA	ROD	TIGE	STANGE	BARRA
118	510.118	PIASTRINA	PLATE	PLAQUE	PLATTE	PLACA
119	510.119	SUPPORTO	SUPPORT	SUPPORT	STÜTZE	SOPORTE

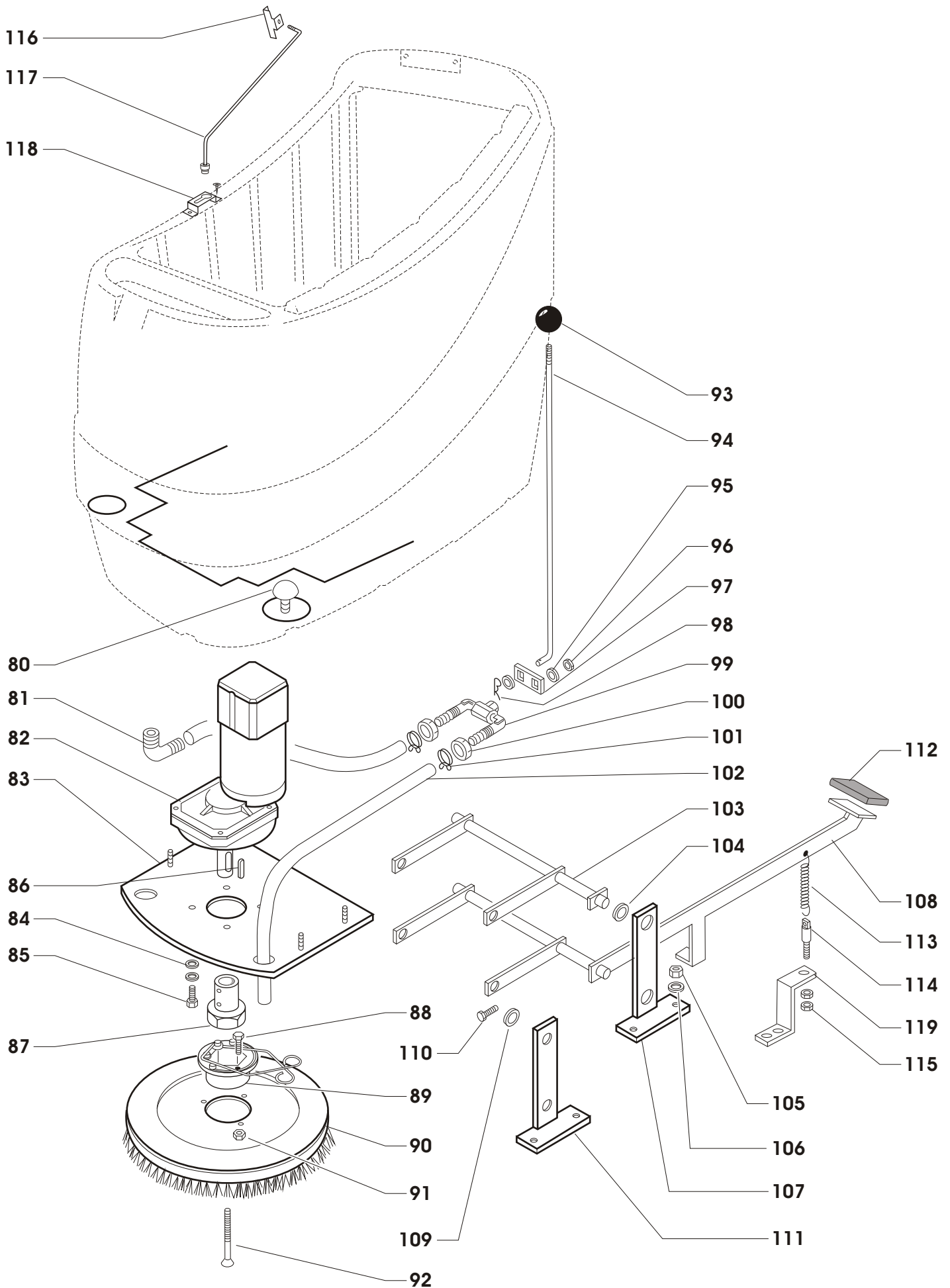



Pos. (°)	Cod. n°	Descrizione	Description	Designation	Benennung	Denominacion
	500.099	GALLEGGIANTE COMPLETO	COMPLETE FLOAT LEVEL	FLOTTEUR COMPLET	SCHWIMMER- VOLLSTANDIG	FLOTADOR NIVEL COMPLETO
140	400.040.1	ANELLO FERMA MOTORE	LOCK RING MOTOR	BAGUE D'ARRET MOTEUR	SICHERUNGSRING MOTOR	ANILLO DE FIJACION MOTOR
141	501.160	MANICOTTO	SLEEVE	MANCHON	HÜLSE	MANGUITO
142	500.257.3	MOTORE ASPIRAZIONE	SUCTION MOTOR	MOTEUR DE ASPIRATION	SAUGMOTOR	MOTOR DE ASPIRACION
143	500.071	GUARNIZIONE	SEAL	JOINT	DICHTUNG	JUNTA
144	510.144	TIRANTE	TIE ROD	TIRANT	ZUGSTANGE	TIRANTE
145	500.070	RETE	NET	GRILLE	GITTER	RED
146	500.069	SPUGNA	SPONGE	ESPONGE	SCHWAMM	ESPONJA
147	500.068	SUPPORTO	SUPPORT	SUPPORT	STÜTZE	SOPORTE
148	500.094	GALLEGGIANTE	FUEL LEVEL	MOUCHARD	SCHWIMMER	NIVEL
149	500.067	GUARNIZIONE	SEAL	JOINT	DICHTUNG	JUNTA
150	510.150	SERBATOIO	TANK	RESERVOIR	BEHAELTER	TANQUE
151	430.311	DADO	NUT	ECROU	MUTTER	TUERCA
152	850.317	DADO	NUT	ECROU	MUTTER	TUERCA
153	430.231	DADO	NUT	ECROU	MUTTER	TUERCA
154	430.118	RONDELLA	WASHER	RONDELLE	UNTERLEGSSCHEIBE	ARANDELA
155	501.180	SQUADRETTA	SQUARE	EQUERRE	WINKEL	ESCUADRETA
156	430.120	VITE	SCREW	VIS	SCHRAUBE	TORNILLO
157	510.157	MOLLA	SPRING	RESSORT	FEDER	RESORTE
158	500.212	COPIGLIA	SPLIT PIN	GOUPILLE	SPLINT	CHAVETA
159	510.159	STAFFA	YOKE	ETRIER	SPANNEISEN	ESTRIBO
163	500.193	PERNO	PIN	GOUJON	BOLZEN	PERNO
164	500.219	VITE	SCREW	VIS	SCHRAUBE	TORNILLO
165	501.187	LEVA	LEVER	LEVIER	HEBEL	PALANCA
166	501.188.1	SQUADRETTA	SQUARE	EQUERRE	WINKEL	ESCUADRETA
167	500.141	MOLLA	SPRING	RESSORT	FEDER	RESORTE
168	400.133	TIRANTE	TIE ROD	TIRANT	ZUGSTANGE	TIRANTE
169	501.191	SUPPORTO	SUPPORT	SUPPORT	STÜTZE	SOPORTE
170	500.223.1	POMOLO	KNOB	POIGNEE	GRIFF	PUNO
171	500.222.1	REGOLATORE	REGULATOR	REGULATEUR	REGLER	REGULADOR
172	430.078	DADO	NUT	ECROU	MUTTER	TUERCA
173	500.219	VITE	SCREW	VIS	SCHRAUBE	TORNILLO
174	500.195	PUNTONE	CROSS MEMBER	TRAVERSE	QUERTRÄGER	TRAVERSANO
175	710.178	DISTANZIALE	SPACER	ENTRETOISE	DISTANZSTÜCK	SEPARADOR
176	501.198	LEVA	LEVER	LEVIER	HEBEL	PALANCA
177	500.194	SPINA ELASTICA	ELASTIC PIN	GOUPILLE	ELASTISCHER STIFT	ENCHUFE ELASTICO
178	400.040	POMOLO	KNOB	POIGNEE	GRIFF	PUNO
179	510.179	VASCA	VAT	CUVE	WANNE	CUBA
180	400.031	TAPPO	PLUG	BOUCHON	VERSCHLUSS	TAPON
181	500.225	TUBO	PIPE	TUYAU	ROHR	TUBO
182	400.021	FERMATUBO	PIPE STRAPP	SERRE - TUBE	ROHRHALTER	SUJETATUBO
183	430.194	VITE	SCREW	VIS	SCHRAUBE	TORNILLO
184	500.154	COPRIPEDALE	PEDAL COVER	COUVRE PEDALE	PEDALKAPPE	CUBREPEDAL
185	510.185	PEDALE	PEDAL	PEDALE	PEDAL	PEDAL
186	500.225	TUBO	PIPE	TUYAU	ROHR	TUBO
187	500.225	TUBO	PIPE	TUYAU	ROHR	TUBO
188	500.226	FASCETTA	HOSE COLLORS	BANDE DE SERRAGE	SHELLE	BANDA
189	510.189	LISTAANTERIORE	FRONT STRIP	BARRE AVANT	VORDERE LEISTE	TOPE ANTERIOR
190	510.190	GOMMA PARA	CREPE RUBBER	CAOUTCHOUC CREPE	PARAGUMMI	GOMA PARA
191	430.173	VITE	SCREW	VIS	SCHRAUBE	TORNILLO
192	500.023	RUOTA PARACOLPI	BUFFER WHEEL	ROUE - BUTEE	PRELLRAD	RUEDA GUARDA- CHOUQUES
193	500.212	COPIGLIA	SPLIT PIN	GOUPILLE	SPLINT	CHAVETA
194	700.124	DADO	NUT	ECROU	MUTTER	TUERCA
195	510.195	TERGIPAVIMENTO COMPLETO	COMPLETE FLOOR WASHING	NETTOYAGE COMPLET	FUSSBODENWISCHER VOLLSTANDIG	BOQUILLA COMPLETA
196	510.196	TERGIPAVIMENTO CORPO	FLOOR WASHING BODY	CORPS NETTOYAGE	KOERPER - FUSSBODENWISCHER	CUERPO BOQUILLA
197	510.197	GOMMA PARA	CREPE RUBBER	CAOUTCHOUC CREPE	PARAGUMMI	GOMA PARA
198	710.177	RUOTA	WHEEL	ROUE	RAD	RUEDA
199	510.199	LISTAPOSTERIORE	BACK STRIP	BARRE POSTERIEUR	HINTER LEISTE	TOPE TRASERO
200	500.219	VITE	SCREW	VIS	SCHRAUBE	TORNILLO
201	410.105.1	TIRANTE	TIE ROD	TIRANT	ZUGSTANGE	TIRANTE
202	850.280.1	PERNO	PIN	GOUJON	BOLZEN	PERNO
203	710.176	VITE	SCREW	VIS	SCHRAUBE	TORNILLO
204	510.204	SUPPORTO	SUPPORT	SUPPORT	STÜTZE	SOPORTE

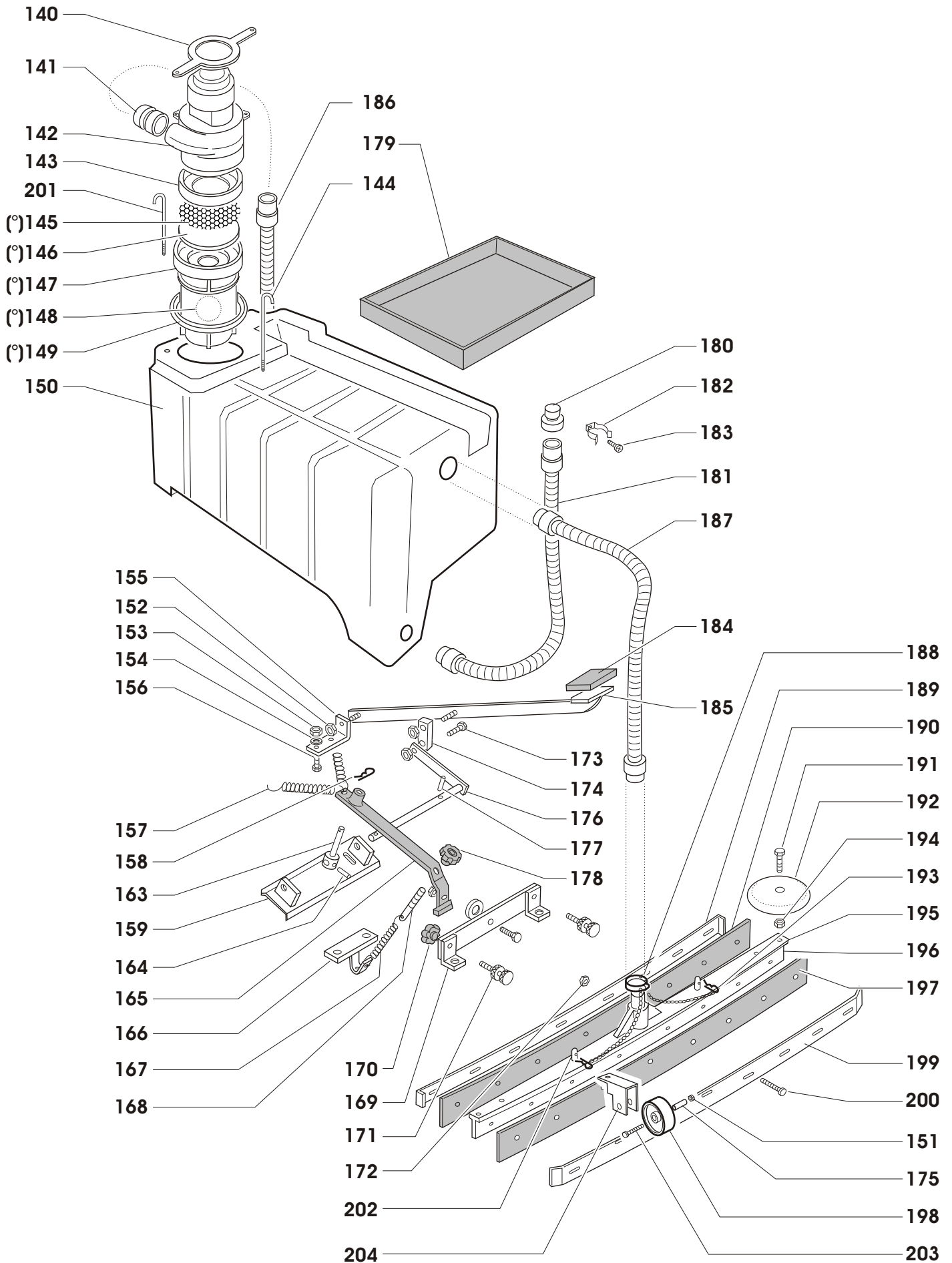



Pos.	Cod. n°	Descrizione	Description	Designation	Benennung	Denominacion
230	430.236.2	RUOTA	WHEEL	ROUE	RAD	RUEDA
231	501.236	LINGUETTA	TANG	LANGUETTE	FEDERKEIL	LANGUETA
232	430.182	DADO	NUT	ECROU	MUTTER	TUERCA
233	510.233	SQUADRETTA	SQUARE	EQUERRE	WINKEL	ESCUADRETA
234	501.293	REGOLATORE	REGULATOR	REGULATEUR	REGLER	REGULADOR
235	510.235	GUAINA	SHEATHING	GAINÉ	ÜBERZUG	RIVESTIMIENTO
236	510.236	PIASTRA	PLATE	PLAQUE	PLATTE	PLACA
237	510.237	MOTO DIFFERENZIALE	MOTOR	MOTEUR	MOTOR	MOTOR
238	500.204	RUOTAPIVOTTANTE	SWIVEL CASTOR	ROULETTE A TIGE	LENKROLLE	RUEDECILLAS FIJACION
239	510.157	MOLLA	SPRING	RESSORT	FEDER	RESORTE
240	430.115	PERNO	PIN	GOUJON	BOLZEN	PERNO
241	501.298	MORSETTO	CLAMP	ETAU	ZWINGE	GRAPA
242	700.248	CAVO	CABLE	FIL	KABEL	CABLE
243	850.033	DADO IN GABBIA	NUT CLIP	ECROU A CAGE	MUTTER - KAFIG	TUERCA A JAULA
244	430.120	VITE	SCREW	VIS	SCHRAUBE	TORNILLO
245	430.118	RONDELLA	WASHER	RONDELLE	UNTERLEGSSCHEIBE	ARANDELA
246	430.182	DADO	NUT	ECROU	MUTTER	TUERCA
247	430.120	VITE	SCREW	VIS	SCHRAUBE	TORNILLO
248	510.248	SEEGER	RING	ANNEAU	RING	ANILLO
249	510.249	ANELLO RASAMENTO	RING	ANNEAU	RING	ANILLO
250	501.248	CUSCINETTO	BEARING	BEARING	LAGER	RODAMIENTOS
251	501.246	GUARNIZIONE	SEAL	JOINT	DICHTUNG	JUNTA
252	510.237.1	MOTORE	MOTOR	MOTEUR	MOTOR	MOTOR

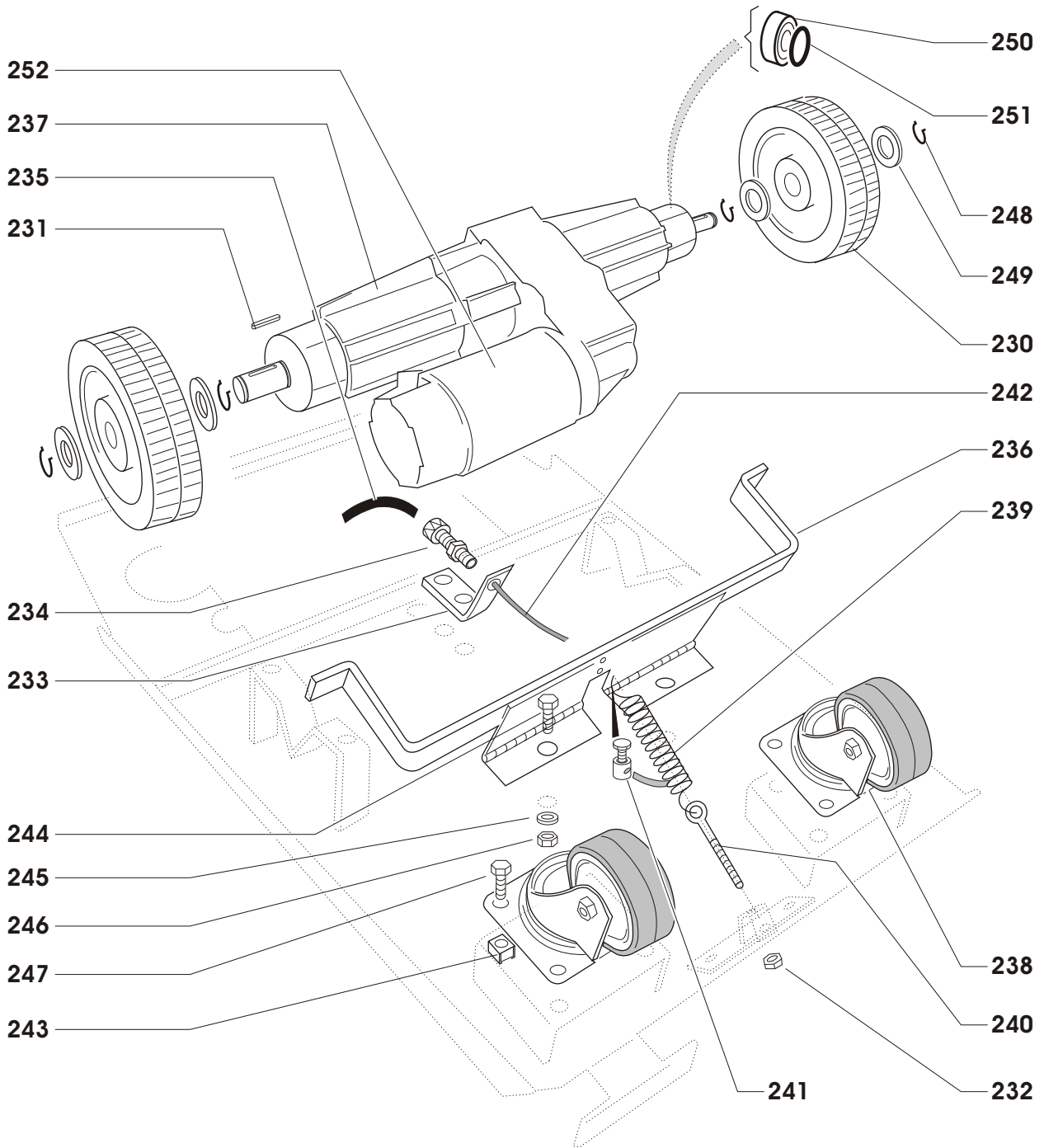



Pos.	Cod. n°	Descrizione	Description	Designation	Benennung	Denominacion
310	501.310.1	SPIA BATTERIA	BATTERY PILOT LIGHT	LAMPE TEMOIN BATTERIE	KONTROLLAMPE - BATTERIE	LAMPARAPILOTO BATERIA
311	850.416	INTERRUTTORE A CHIAVE	KEY SWITCH	INTERRUPTEUR A CLE	SCLUSSEL - SCHALTER	INTERRUPTOR LLAVE
312	430.302	INTERRUTTORE SPAZZOLA	BRUSH SWITCH	INTERRUPTEUR BROSE	BUERSTE - SCHALTER	INTERRUPTOR CEPILLO
313	430.302	INTERRUTTORE ASPIRAZIONE	SUCTION SWITCH	INTERRUPTEUR ASPIRATION	SAUG - SCHALTER	INTERRUPTOR ASPIRACION
314	850.472	POTENZIOMETRO	POTENTIOMETER	POTENTIOMETRE	POTENTIOMETER	POTENCIOMETRO
315	430.318	MICRO	MICRO SWITCH	MICRO	MIKRO	MICRO
316	430.293	TELERUTTORE SPAZZOLA	BRUSH REMOTE CONTROL	TELERUPTEUR BROSE	BUERSTE - FERNSCHALTER	TELEINTERRUPTOR CEPILLO
317	430.293	TELERUTTORE ASPIRAZIONE	SUCTION REMOTE CONTROL	TELERUPTEUR ASPIRATION	SAUG - FERNSCHALTER	TELEINTERRUPTOR DE ASPIRACION
318	850.423	FUSIBILE	FUSE	FUSIBLE	SICHERUNG	FUSIBLE
319	501.319	FUSIBILE	FUSE	FUSIBLE	SICHERUNG	FUSIBLE
320	700.231	FUSIBILE	FUSE	FUSIBLE	SICHERUNG	FUSIBLE
321	510.237	MOTO DIFFERENZIALE	MOTOR	MOTEUR	MOTOR	MOTOR
322	430.066.B	MOTORIDUTTORE	REDUCER MOTOR	REDUCTEUR-MOTEUR	REDUZIERER-MOTOR	REDUCTOR-MOTOR
323	500.257.3	MOTORE ASPIRAZIONE	SUCTION MOTOR	MOTEUR ASPIRATION	SAUG MOTOR	MOTOR DE ASPIRACION
324	500.258.1	CONNETTORE	CONNECTION	CONNECTEUR	ANSCHLUSS	CONNECTOR
325	500.258.1	CONNETTORE	CONNECTION	CONNECTEUR	ANSCHLUSS	CONNECTOR
326	500.263	CAVO (-)	CABLE	FIL	KABEL	CABLE
327	500.266	CAVO (+)	CABLE	FIL	KABEL	CABLE
328	500.262	PONTE	BRIDGE	PONT	BRUECKE	PUENTE
329	500.250.4 500.250.10	BATTERIA 12V 120A BATTERIA 12V 140A	BATTERY 12V 120A BATTERY 12V 140A	BATTERIE 12V 120A BATTERIE 12V 140A	BATTERIE 12V 120A BATTERIE 12V 140A	BATERIA 12V 120A BATERIA 12V 140A
330	510.330.1	SCHEDA ELETTRONICA	ELECTRONIC CARD	CARTE ELECTRONIQUE	ELEKTRONISCHE KARTE	TARJETA ELECTRONICA
331	430.300	MANOPOLA	KNOB	HANDLE	GRIFF	MANDO
332	510.332	PULSANTE RETROMARCIA	REVERSE RUNNING PUSH BUTTON	BOUTON MARCHE ARRIERE	KNOPF RÜCKWÄRTSGANG	BOTON MARCHA ATRAS



**DICHIARAZIONE-DECLARATION-DECLARATION-ERKLÄRUNG
DECLARACION**

**DICHIARAZIONE DI CONFORMITÀ: la
DECLARATION OF CONFORMITY: (company name)
DECLARATION DE CONFORMITE: la
ÜBEREINSTIMMUNGSERKLÄRUNG
DECLARACION DE CONFORMIDAD**

**OMM lavapavimenti Via Cantu' 8/10
Cinisello Balsamo (MI) - ITALY
Tel. ++39.02.612.83.80 - Fax ++39.02.66.59.49.00**

dichiara sotto la propria esclusiva responsabilità che la/le macchina/e nuova/e:
declares under its own responsibility that the new machine/s:
déclare sous sa responsabilité exclusivement que le/les machine/s nouveau/s:
erklärt unter ausschließlicher eigener Verantwortung, daß die Maschine(n) neu:
declara bajo su propia y exclusiva responsabilidad que la/s máquina/s nueva/s:



500 SFERA

Modello/model/modele/modell/modelo

Matricola /serial number/numero matricule
seriennummer/numero matricula

Anno/year/année/jahr/ano

è/sono conforme/mi alle seguenti norme:
conform/s to the following laws:
est/sont conforme/saux normes:
mit den folgenden Normen übereinstimmen:
está/están conforme/s a lassiguientes normas:

EN55014/94 - EN60555-2-3/82 - EN50082-1/92 - EN60335/2/.... - VDE0700T205

ed inoltre è/sono fabbricata/e nel rispetto delle direttive e/o decreti:
and moreover is/are built according to the directives and/or decrees:
et est/sont fabriquées, en outre, conformément aux directives et/ou décrets:
und daß sie unter Einhaltung folgender Verordnungen und/oder Dekrete hergestellt worden (sind):
y que además ha/han sido fabricada/s en conformidad con las directivas y/o decretos:

89/336/CEE - 73/23/CEE - 98/37/CEE - DPR547 - DPR224

l'amministratore:	CLAUDIO MESCOLI	Firma	Data
executive officer:	CLAUDIO MESCOLI	Signed	Date
l'administrateur:	CLAUDIO MESCOLI	Signature	Date
der Geschäftsführer:	CLAUDIO MESCOLI	Firma	Datum
el administrador:	CLAUDIO MESCOLI	Firma	Fecha