

05-05

SPARE PARTS LIST - GD 910

BOOK B

COMMERCIAL DRY VACUUM CLEANER

B

6.3.1

1



DESCRIPTION

PLAN

Cover & Container

B - 6.3.1 - 3

Filters, fan units & cordsets

B - 6.3.1 - 5

Nozzles, tubes & hoses

B - 6.3.1 - 7

B

6.3.1

2

COVER & CONTAINER PARTS

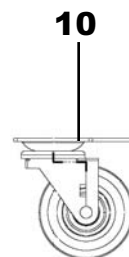
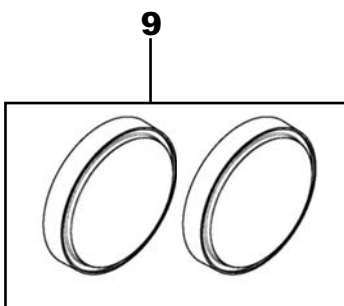
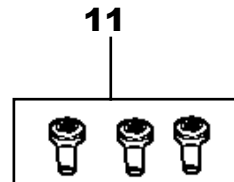
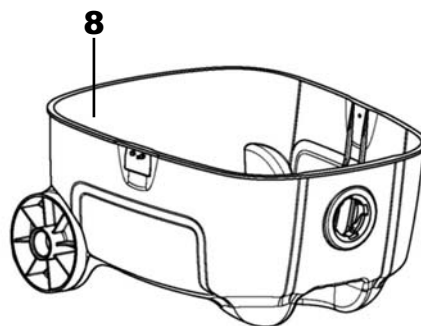
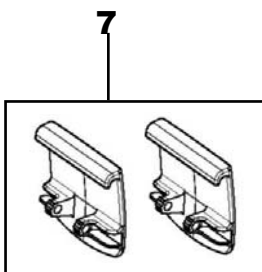
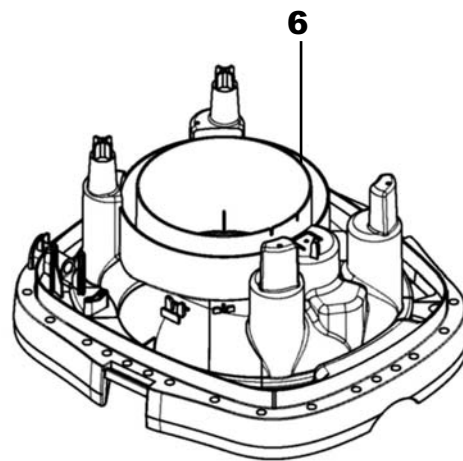
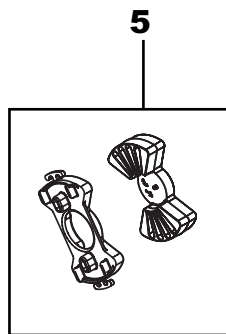
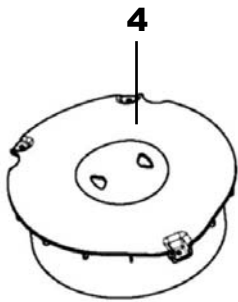
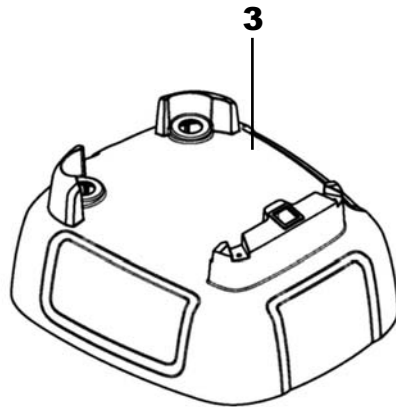
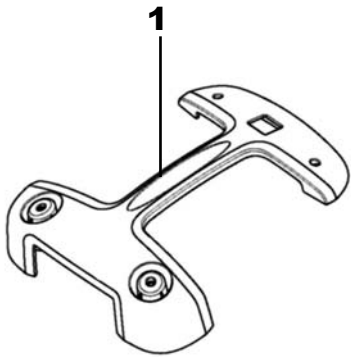

05-05	SPARE PARTS LIST - GD 910	BOOK B		
06-12	COVER & CONTAINER PARTS	B	6.3.1	3

Item.No.	Part No	Qty.	Description	Note	EAN code
1	147 0654 500	1	Handle		7319519651683
2	140 5496 510	1	Switch		7319519631739
3	147 0655 500	1	Top cover		7319519651690
3	147 0655 510	1	Top cover	UL-approved	7319519651706
4	147 0659 500	1	Noise trap, Domel fan		7319519651744
4	147 0659 510	1	Noise trap, Domel fan	UL-approved	7319519651751
4	>> 147 1151 500	1	Noise trap, new fan		7319519661217
4	>> 147 1151 510	1	Noise trap, new fan	UL-approved	
5	147 0660 500	1	Motor suspension kit	Adapter and damper	
6	147 0656 500	1	Chassis		7319519651713
6	147 0656 510	1	Chassis	UL-approved	7319519651720
7	147 0677 500	2	Latches, kit	2 latches	7319519651799
8	147 0657 500	1	Container cpl.	With latches and wheels	7319519651737
9	140 8458 500	2	Wheels rear, kit	2 Wheels	7319519632002
10	140 8445 500	1	Wheel castor		7319519629347

>> Means: New or changed ref. number or/and changed/new specifications

B

6.3.1

4

FILTERS, FAN UNITS & CORDSETS

1

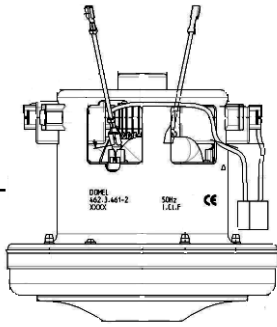

2

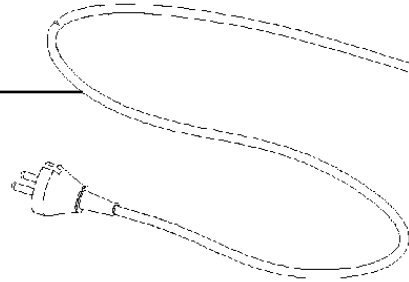

1b

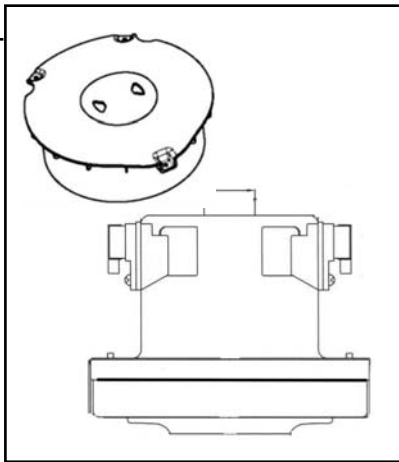

2B

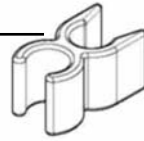

3

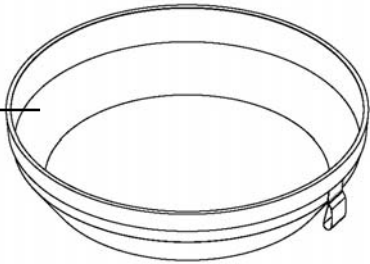

4

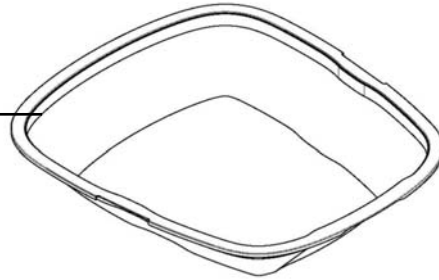

5

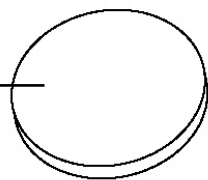

6

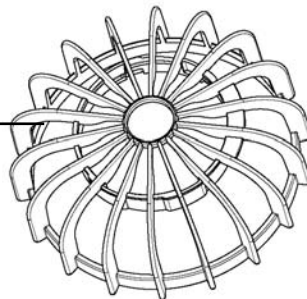

07-02	SPARE PARTS LIST - GD 910	BOOK B		
07-03	FILTERS, FAN UNITS & CORDSETS	B	6.3.1	5

Item.No.	Part No	Qty.	Description	Note	EAN code
1	P 147 0674 500	1	Fan unit 230-240V	w.thermal protector	7319519651256
1	P 147 0673 500	1	Fan unit 120V	w.thermal protector	7319519651263
1	P 147 0672 500	1	Fan unit 100V	w.thermal protector	7319519651270
1b	>> 147 1152 500	1	Fan unit 220-240V	w. noise trap, wires	7319519661019
1b	>> 147 1167 500	1	Fan unit 120V	w. noise trap, wire	7319519661026
1b	>> 147 1168 500	1	Fan unit 100V	w. noise trap, wires	7319519661033
2	12222501	1	Cord set EU 10,5 M		5715492008056
2	12222503	1	Cord set UK 10,5 M		5715492008063
2	12222506	1	Cord set AU/NZ 10,5 M		5715492008070
2	147 0716 510	1	Cord set US/TW 10,5 M (32 ft)		7319519647259
2	>> 140 6702 500	1	Cord set JP 15 m		7319519651652
2	147 0504 500	1	Cord set CN 10,5 M		7319519651676
2B	147 0808 500	1	Cord clip		7319519656503
2B	147 0808 510	1	Cord clip US/JP/TW		7319519656497
3	147 0663 500	1	Sackfilter, inner	Optional	7319519651768
4	147 0678 500	1	Sackfilter, outer	Standard	7319519651805
5	147 0670 500	3	Filter, motor	3 psc.	7319519651782
6	147 0669 500	1	Basket, sackfilter		7319519651775

>> Means: New or changed ref. number or/and changed/new specifications

P Means: Depleted when no longer on stock. Replaced by new items.

B

6.3.1

6

NOZZLES, HOSES & TUBES 32 mm

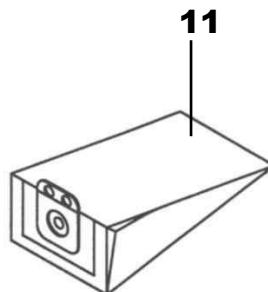
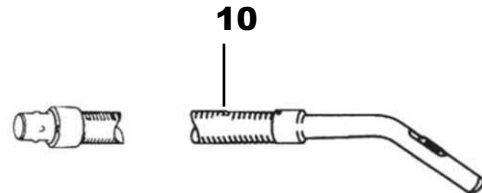
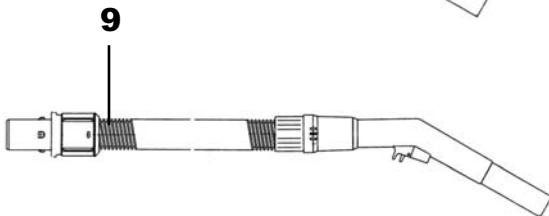
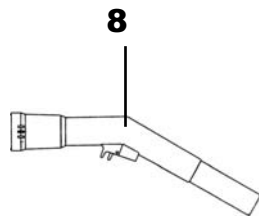
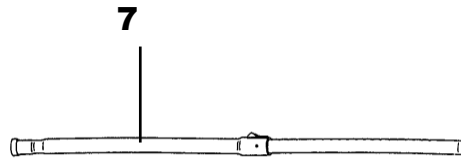
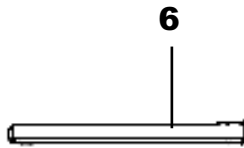
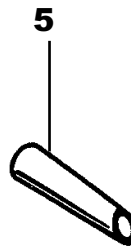
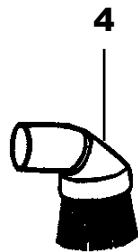
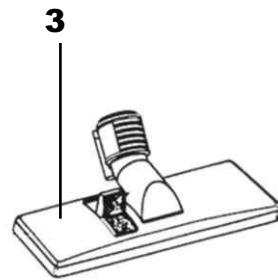
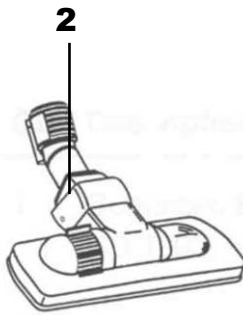
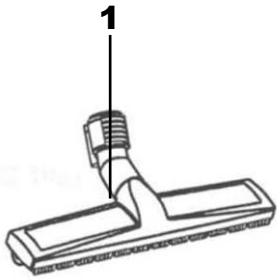

05-05	SPARE PARTS LIST - GD 910	BOOK B		
	NOZZLES, HOSES & TUBES 32 mm	B	6.3.1	7

Item.No.	Part No	Qty.	Description	Note	EAN code
1	140 6700 540	1	Nozzle multi surface, park.clip	Black	7319519636680
2	12018503	1	Nozzle combi, park.clip	Grey	7319519632217
3	12019401	1	Nozzle combi, park.clip	Grey	5715492003372
4	11276901	1	Nozzle brush	Grey	5715492005451
4b	140 8244 000	1	Nozzle brush	Black	7319519412000
5	81140900	1	Nozzle crevice	Grey	7319519494426
5	22302100	1	Nozzle crevice 150 mm	Black	5715492009237
6	011 6431 500	1	Extension tube aluminium	L=500 mm	7319519631685
6	140 8246 040	1	Extension tube steel	L=500 mm	7319519607864
6	140 8246 000	1	Extension tube chrome steel	L=500 mm	7319519300048
7	81906500	1	Extension tube telescopic	Steel	5715492011872
8	140 7584 500	1	Hose handle, black		7319519631999
9	147 0765 500	1	Hose complete, black		7319519651829
10	12018001	1	Hose complete, grey		5715492003426
11	140 8618 000	10	Dustbag 10 L	10 pcs.	7319519628364
11	22251800	1	Cloth dustbag		7319519627305

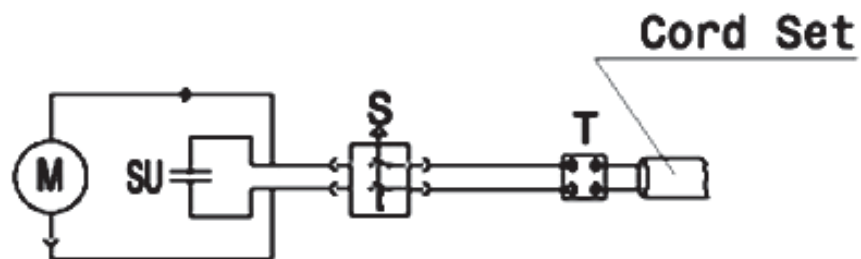
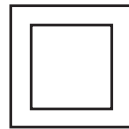

- M Fan Unit
S Switch
SU Suppressor Unit
T Terminal Block

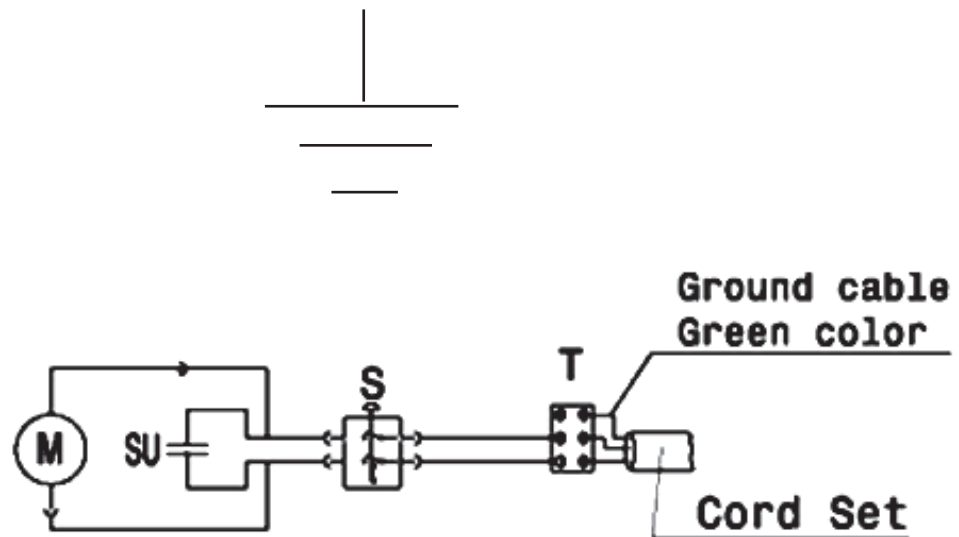

- M Fan Unit
S Switch
SU Suppressor Unit
T Terminal Block